



87-96 CURRENT F-150 BOX BOARD

IN253
10/22/03

DRILLING INTO BODY AND FRAME IS REQUIRED.

INSTALLATION PARTS LIST:		QTY. DESCRIPTION		QTY. DESCRIPTION	
1	RUNNING BOARD	1	DRIVER & 1 PASSENGER	2	5/16" CUP NUT
1	STONE GUARD	1	LEFT & 1 RIGHT	10	5/16"x 3/4" BOLT
8	3/8"x1 SELF TAPPING SCREW	8	5/16-18 HEX WASHER HEAD NUT	2	FLAT BRACKET, FL74
6	#14x3/4" SHEET METAL SCREW	2	FLAT BRACKET, FL73 D&P	2	HORIZONTAL BRACKET, SUPPORT, 3124F
4	1/4x5/8" SQUARE HEAD SCREW	2	1/4-20 HEX NUT	2	#14 X 3/4 TEK SCREW
1	1/4-20 HEX NUT				
1	END CAP	1	LEFT & 1 RIGHT		

TOOLS REQUIRED: 5/16" DRILL • 1/2" HEX SOCKET • 1/2" WRENCH • 5/16" NUT DRIVER • 3/8" NUT DRIVER

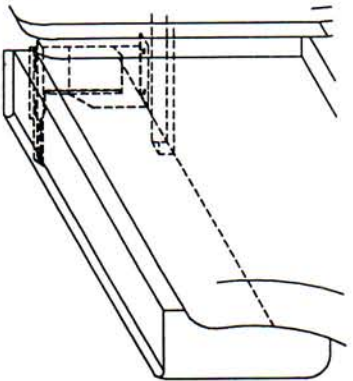

BOX BRACKET LOCATION (DRIVERS SIDE SHOWN)

1 LOCATE THE FIRST BED CROSS BRACE BEHIND THE CAB

2 BRACKET ASSEMBLY ASSEMBLE WITH 5/16" BOLTS

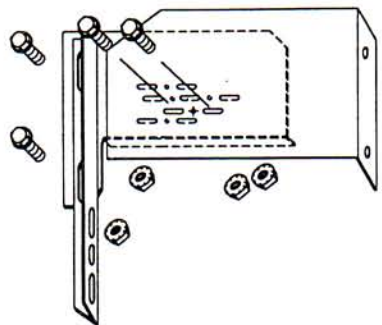

3 PREDRILL A 5/16" HOLE NEAR THE END OF THE CROSSBRACE SLIDE NUT INTO END OF CROSS BRACE AT BRACKET LOCATION

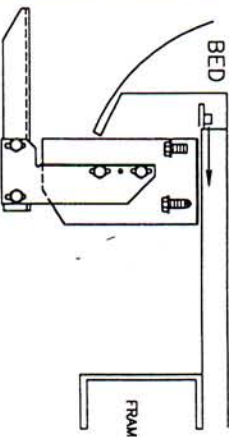

MOUNT AT LOCATION SHOWN AT 1

4 BEND STONE GUARD BY HAND AND KNEE TO FIT THE WHEEL WELL BEFORE INSTALLING TO RUNNING BOARD

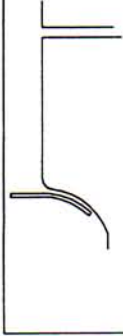

5 FASTEN REAR STONE GUARD TO BOARDS WITH 3/8" SELF TAPPING BOLT. BEND STONE GUARD BY HAND AND KNEE TO FIT THE WHEEL WELL

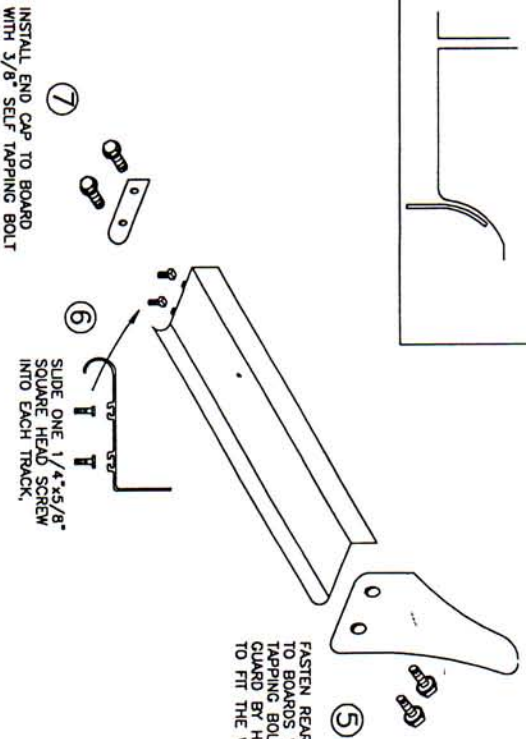

7 INSTALL END CAP TO BOARD WITH 3/8" SELF TAPPING BOLT

6 SLIDE ONE 1/4"x5/8" SQUARE HEAD SCREW INTO EACH TRACK.

8 HOLD BOARD IN PLACE WITH THE FRONT RESTING ON THE BOX BRACKET. BE SURE THAT 1/4" BOLTS ARE PLACED INTO THE BRACKET STEP SUPPORT.

9 SCREW THROUGH STONE GUARD INTO FENDERWELL UP USING #14 BY 3/4 SHEET METAL SCREWS. MAKE SURE YOU DRILL INTO METAL 3 PLACES AT EACH STONE GUARD

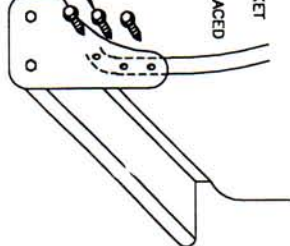

10 SECURE BOARD TO BRACKET WITH (2) 1/4" NUTS

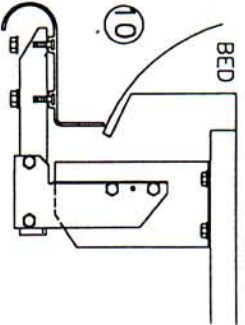

11 WITH BOARD LEVEL, TIGHTEN ALL LOOSE BOLTS

12 REPEAT FOR OTHER SIDE

NEWBOX 10/22/03