



# 87-96 FORD F150 EXTENDED CAB

IN241  
08/22/03

DRILLING INTO BODY AND FRAME IS REQUIRED.

### INSTALLATION PARTS LIST:

QTY.	DESCRIPTION	QTY.	DESCRIPTION
1	RUNNING BOARD 1 DRIVER & 1 PASSENGER	4	1/4" CARRIAGE BOLT
1	STONE GUARD 1 LEFT & 1 RIGHT	14	5/16" x 3/4" BOLT
8	3/8" x 1 SELF TAPPING SCREW	14	5/16-18 HEX WASHER HEAD NUT
14	#14x3/4" SHEET METAL SCREW	4	FLAT BRACKET, FL20
8	1/4x5/8" SQUARE HEAD SCREW	4	FLAT BRACKET, FL75
12	1/4-20 HEX NUT	4	HORIZONTAL BRACKET, SUPPORT, 5124F
1	END CAP 1 LEFT & 1 RIGHT		

**TOOLS REQUIRED:** 5/16" DRILL • 1/2" HEX SOCKET • 1/2" WRENCH • 5/16" NUT DRIVER • 3/8" NUT DRIVER

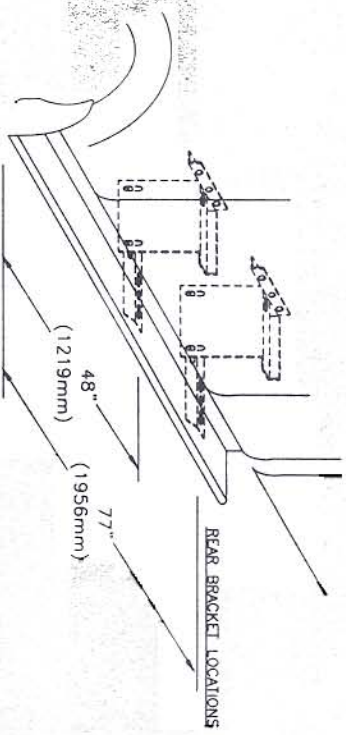

① MEASURE FROM FRONT WHEEL WELL TO BRACKET LOCATION  
MARK THIS DIMENSION ON THE PINCH WELD

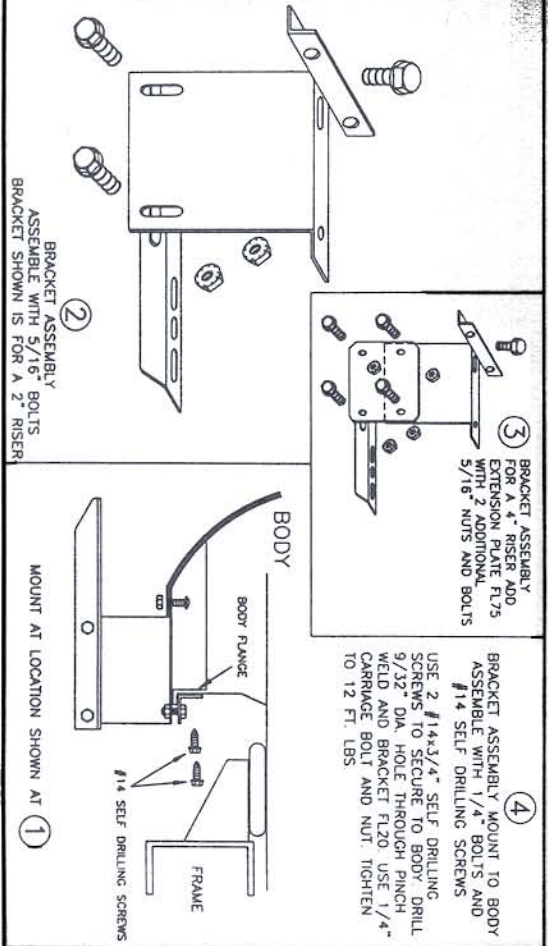

⑤ BEND STONE GUARD BY HAND AND KNEE TO FIT THE WHEEL WELL BEFORE INSTALLING TO RUNNING BOARD

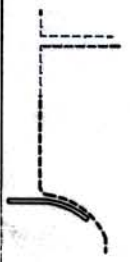

⑧

INSTALL END CAP TO BOARD WITH 3/8" SELF TAPPING BOLT

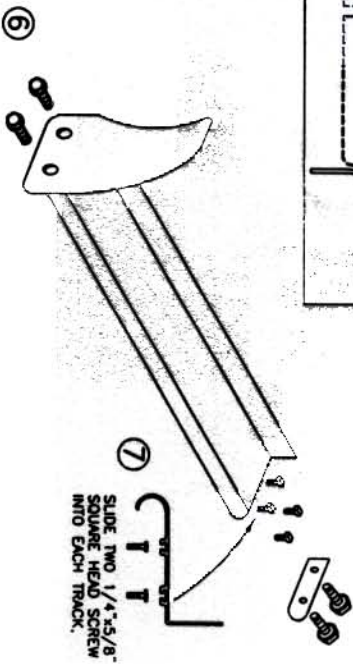

⑨

HOLD BOARD IN PLACE WITH THE REAR RESTING ON THE BACK BRACKET

⑩

SCREW THROUGH STONE GUARD INTO FENDERWELL LIP USING #14 BY 3/4 SELF DRILLING SCREWS. MAKE SURE YOU DRILL INTO METAL

3 PLACES AT EACH STONE GUARD

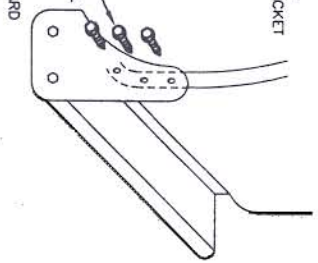

NOTE: BE SURE THAT 1/4" BOLTS ARE PLACED INTO THE BRACKET STEP SUPPORT

⑪

SECURE BOARD TO BRACKET WITH (2) 1/4" NUTS

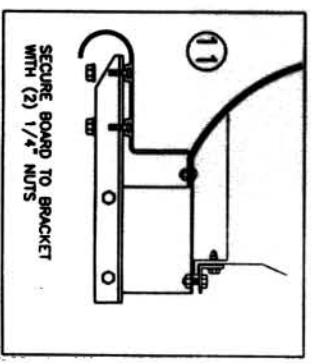

⑬

REPEAT FOR OTHER SIDE

WITH BOARD LEVEL TIGHTEN ALL LOOSE BOLTS