

This part should only be installed by personnel who have the necessary skill, training and tools to do the job correctly and safely. Incorrect installation can result in personal injury, vehicle damage and / or loss of vehicle control.

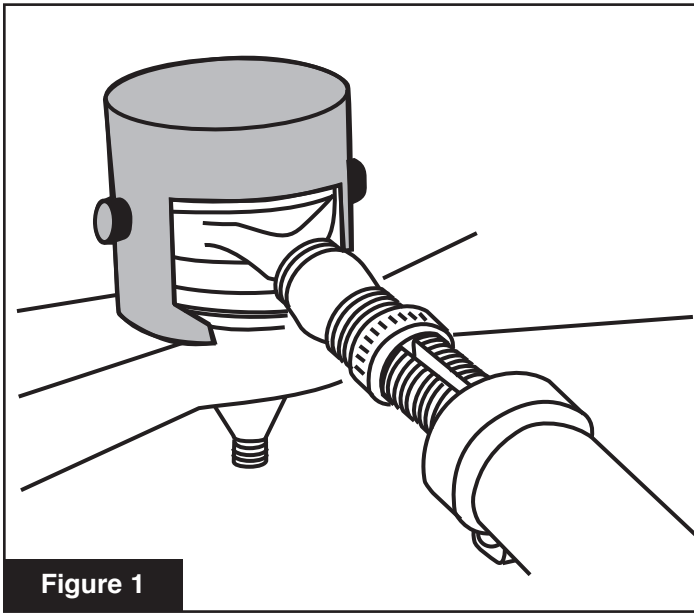

Figure 1

Note: Start vehicle and center the steering wheel. Lock the steering wheel in place with a steering wheel holder. Shut off the vehicle. Begin the following alignment procedure with the side of the vehicle that requires the most change.

CAUTION: The outer tie rod housings on these vehicles have a tendency to rotate off the center of the ball stud. This can cause abnormal tire wear and alter the toe settings. Therefore, it's very important that the outer tie rod housing be secured during this procedure.

Instructions

1. Install the tie rod end stabilizer socket (**Figure 1**) over the tie rod end housing and secure the housing by tightening the setscrews.
2. Refer to (**Figure #2**). Separate the two-piece nut and install the top half (**A**) with the key down into the slot on the adjusting sleeve, then install lower half of nut (**B**) over the pins on the upper part of the nut and push together.

NOTE: Clean adjusting sleeve before installing the nut halves. Do NOT FORCE nut halves onto the sleeve.

3. Loosen the clamp bolt (**C**) on the tie rod. using a 1/2" drive ratchet and extension with the large hex end wrench supplied (**D**), adjust the toe by sliding the wrench over the two-piece nut and turning either direction.

CAUTION: It may be necessary to hold the inner tie rod from turning with a suitable tool to keep from damaging the inner rod bushing.

4. Repeat steps 1 through 3 for the opposite side.
5. With the tie rod stabilizer still tightly installed over the tie rod end housing, tighten the sleeve clamp (**C**) to manufacturer's specifications.
6. Upon removal of the tie rod end stabilizer socket, check to ensure that the tie rod housing is perpendicular to the ball stud.
7. Repeat steps 5 and 6 on the other side of the vehicle.

Always check for proper clearance between suspension components and other components of the vehicle.

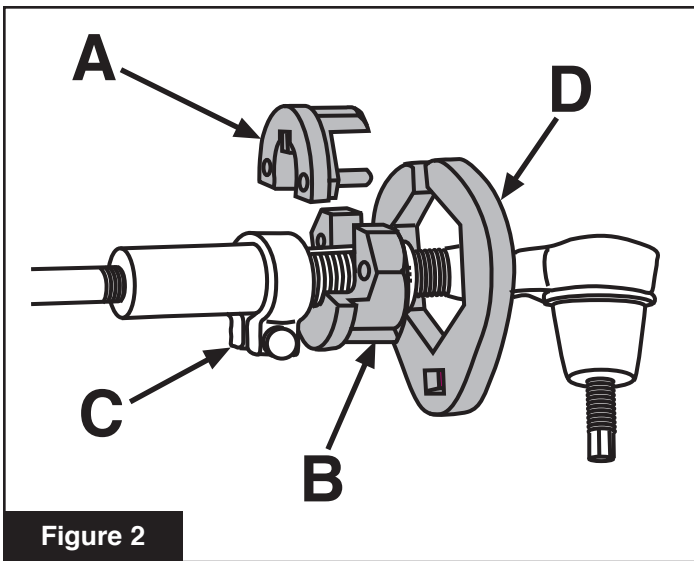

Figure 2



Specialty Products Company®