



INSTALLATION INSTRUCTIONS

Competition Bolt-on Ladder Bars - Part No. 20462

1970 – 81 Chevrolet Camaro/Pontiac Firebird

Thank you for your purchase from Lakewood Industries. For technical assistance, please call 216-688-8300 Monday thru Friday 8:30 AM to 5:00 PM EST.

CAUTION: INSTALLATION OF THIS PRODUCT REQUIRES WORKING UNDER THE VEHICLE. IT IS THE RESPONSIBILITY OF THE INSTALLER TO ENSURE A SAFE WORKING ENVIRONMENT. THE USE OF AN AUTOMOTIVE LIFT IS RECOMMENDED. MAKE SURE THAT THE VEHICLE IS SAFELY SUPPORTED AND ALWAYS USE JACK STANDS. ALWAYS WEAR SAFETY GLASSES.

WARNING: DUE TO THE TECHNICAL NATURE OF THIS PRODUCT, AND SPECIALIZED EQUIPMENT, PROFESSIONAL INSTALLATION IS RECOMMENDED.

STEP 1

Jack up rear of vehicle, place jackstands under the axle and let all weight down on the jackstands.

STEP 2

If the car is equipped with a stabilizer bar, it must be removed at this point.

STEP 3

Remove two of the four spring perch T-bolt nuts (A) toward the inside of the car (See Illustration)

STEP 4

Carefully pry brake line with a large screwdriver to clear U-bolt. Position traction bar in place and attach U-bolt using nuts and lockwashers supplied. Snug T-bolts up then tighten U-bolt nuts. Tighten these four nuts securely.

STEP 5

Insert rubber brushings into front of traction bar.

STEP 6

Position front pivot bracket as shown. Carefully align bolts with flatwashers (D) and (E) supplied. Be very careful not to cross thread the factory nuts that are captured in the frame. If the car is using stock suspension, the upper hole (B) must be used. If the car is raised at axle 1 1/2 to 2", the lower holes must be used. If the car is raised higher, new extended brackets must be fabricated. If the car stock height or lower, it may be necessary to trim the bracket as shown (dotted line) for ground clearance.

STEP 7

Align front traction bar holes with frame bracket holes and insert 1/2" bolt with self locking nut supplied. This bolt and nut should be tightened to pull the side plates in to crush the rubber bushings slightly.

STEP 8

Two 3/8" holes (F) must be drilled in the floor pan as shown. The rear seat cushion must be removed and the holes drilled from the bottom through the front mounting bracket holes. After drilling holes insert bolts supplied through bracket, floor pan, and back up plate. Attach lockwashers and nuts. Tighten securely and seal floor holes with Mr. Gasket silicone #4325 or equivalent.

STEP 9

Be sure all bolts and nuts are tightened properly. This completes the installation of one side. Install the opposite side exactly the same.

STEP 10

After driving the car for approximately 100 miles, check all bolts and nuts. Retighten if necessary.

Lakewood chassis and suspension products are engineered and manufactured to improve the performance of your vehicle. We encourage you to enjoy using our products safely at a sanctioned racing facility. Please obey all traffic laws.

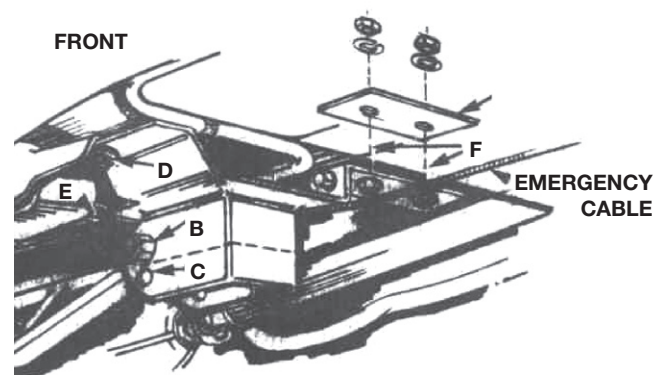
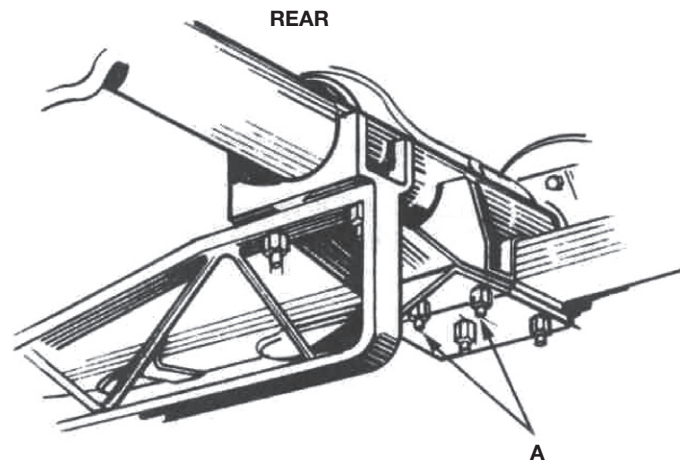

LAKEWOOD IS A TRADEMARK OF PRESTOLITE PERFORMANCE
10601 MEMPHIS AVE #12, CLEVELAND, OH 44144
216.688.8300 FAX 216.688.8306

FORM 97144062
07/11