

**TECHNICAL SUPPORT HOTLINE**

OUR TECHNICAL DEPARTMENT WILL GLADLY ANSWER ANY QUESTIONS YOU MAY HAVE ABOUT OUR PRODUCTS. THEY CANNOT, HOWEVER TELL YOU THE STATUS OF A REPAIR, OR HANDLE OTHER CUSTOMER SERVICE SITUATIONS

IMPORTANT: PACK CAREFULLY IN ORIGINAL CARTON IF POSSIBLE. WE ARE NOT RESPONSIBLE FOR DAMAGE INCURRED IN RETURNING ITEMS FOR REPAIR. A LETTER STATING YOUR EXACT STREET ADDRESS, DAYTIME PHONE NUMBER, AND THE PROBLEM YOU ARE EXPERIENCING SHOULD BE INCLUDED. YOU MUST ALSO ENCLOSE A COPY OF THE ORIGINAL RECEIPT A SPROOF OF DATE OF PURCHASE

PYRAMID CAR AUDIO SERVICE CENTER  
1600 63RD STREET  
BROOKLYN, NY 11204  
1-800-934-2277  
MONDAY THROUGH THURSDAY. 9AM TO 5PM  
FRIDAY 9AM TO 2PM EASTERN.



**USER'S MANUAL**



**PB715X PB915X PB2415X**

**2 CHANNEL MOSFET AMPLIFIER**

**PB615X PB1615X**

**4 CHANNEL MOSFET AMPLIFIER**

**WWW.PYRAMIDCARAUDIO.COM**

**Congratulations** on purchasing the High Speed Power Amplifier. The amplifier has been designed using the latest electronic technology available, allowing you to produce high quality stereo reproduction in mobile applications. This system provides you with low harmonic distortion, a huge considerable amount of reserve voltage and high temperature stability.

**Just enjoy the perfect sound this amplifier takes to you!**

## INSTALLATION

\* Since the amplifier is sensitive to electrical and motor noise and interference from the amplifier may affect your radio reception, try to mount it at least 3 feet away from the receiver. Good locations include under a seat, in the trunk or hatch area.

\* Please remember this is a high power unit which generates high electrical energy and heat. Therefore be sure to install the unit in a place with sufficient airflow, a minimum of dust and no moisture. Allow enough space around the cooling fins to permit reasonable airflow and cooling. It is important to ensure that the cooling fins of the heat sink are not against a panel or a surface preventing air circulation.

\* Never mount the amplifier in a location that is subject to direct sunlight or exposed to moisture. Be sure to mount the amplifier to a strong, solid surface which will not give way under the stress of a sudden stop or accident.

\* When mounting the amplifier on a side wall, try to position it so that the slots in the cooling fins are vertical. Amplifier should not be mounted on the bottom of a rear deck with the fins facing down because the heat will radiate back up into the amplifier. Leave yourself enough room on either side of the amplifier to make all the wire connections and adjust the controls. If you have a subwoofer box in your vehicle, you can mount the amplifier on the outside of the box.

**Caution:** *If you are mounting the amplifier to the vehicle's floor, check beneath the car to be sure your screws won't puncture a brake or gas line.*

### **WARNING!**

Continuous exposure to sound pressure levels over 100dB may cause permanent hearing loss. High power autosound system may produce sound pressure levels well over 130dB, use common sense and practice safe sound please!

## Technische Daten

	PB715X	PB915X	PB2415X	PB615X	PB1615X
Output Power Rating @ 4 Ohms	35Wx2	50Wx2	75Wx2	35Wx4	75Wx4
@ 2 Ohms	55Wx2	100Wx2	150Wx2	55Wx4	150Wx4
@ 1 Ohms	—	—	—	—	—
Bridged @ 4 Ohms	110Wx1	150Wx1	200Wx1	110Wx2	200Wx2
Frequency Response	10Hz~50KHz	10Hz~50KHz	10Hz~50KHz	10Hz~50KHz	10Hz~50KHz
Input Sensitivity	0.1~1.0V	0.1~1.0V	0.1~1.0V	0.2~5.0V	0.2~5.0V
Signal To Noise Ratio	>90dB	>90dB	>90dB	>90dB	>90dB
THD&Noise	<0.01%	<0.01%	<0.01%	<0.01%	<0.01%
High Pass Cross Frequency	120Hz~3KHz	120Hz~3KHz	120Hz~3KHz	120Hz~3KHz	120Hz~3KHz
Low Pass Cross Frequency	50Hz~250Hz	50Hz~250Hz	50Hz~250Hz	50Hz~250Hz	50Hz~250Hz
Subsonic Filter	—	—	—	—	—
Bass EQ	6dB/12dB@45Hz	6dB/12dB@45Hz	6dB/12dB@45Hz	6dB/12dB@45Hz	6dB/12dB@45Hz
Speaker Impedance	2~16 Ω	2~16 Ω	2~16 Ω	2~16 Ω	2~16 Ω
Fuse Size	1x20A	1x30A	1x40A	2x15A	2x30A
Dimensions (LxHxW) mm	185x53x240	200x53x240	250x53x240	280x53x240	360x53x240

\*All specifications subject to change without notice

## 4 CHANNEL AMPLIFIER – APPLICATIONS

PB615X/PB1615X

### 3-CHANNEL MODE

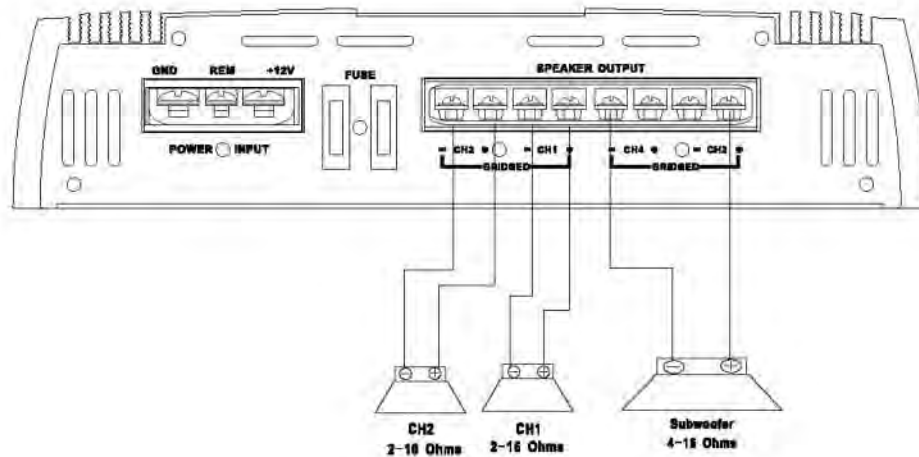
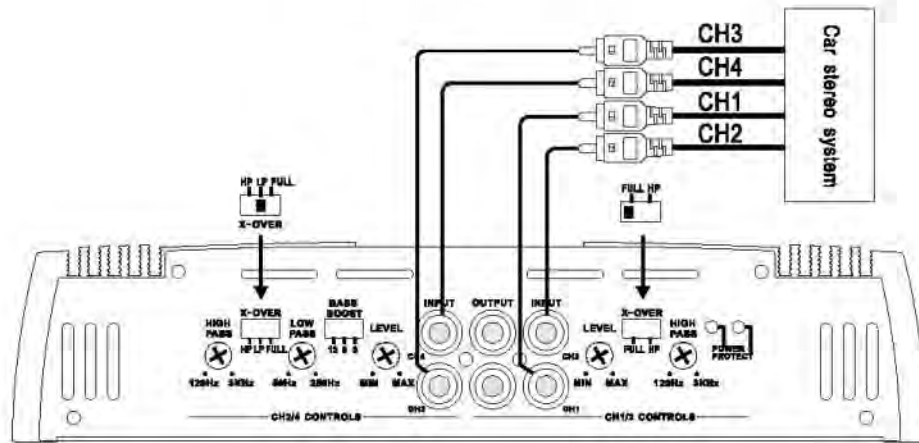

## POWER CONNECTION

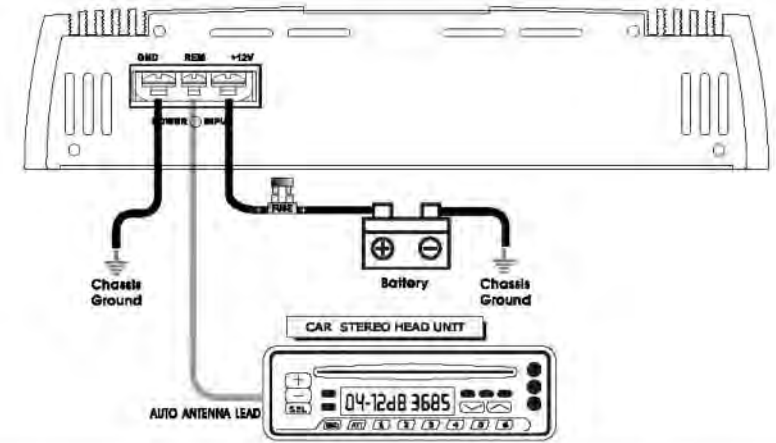

**IMPORTANT!** Before making any connections, disconnect the car's battery until the installation is completed to avoid possible damage to the electrical system

\* The +12V DC power cable should be heavy gauge stranded copper cable with heavy insulation, since it draws power directly from the positive battery terminal. Select the cable gauge at least 10mm<sup>2</sup>. And the ground cable gauge should be the same as the +12V DC.

\* Connect the +12V Power terminal to the battery(+) position terminal. An in-line fuse must be installed in the +12V power cable near the battery less than 50mm. **Without one**, an accidental short circuit could pose a fire hazard and damage your amplifier. Connect the fuse holder to battery, however, do not install fuse at this time.

\* Connect the GROUND Power terminal directly to the battery(-) position terminal or the car chassis. Ensure that all paint or other insulation is removed from around the hole area, and using self tapping screw, securely affix the bare wire ends to the vehicle chassis. Use as short as possible.

\* Many radio's and other music sources have an output terminal for connection of the remote turn on of the power amplifier. CONNECT the output terminal to the amplifier REM control jack. If a radio doesn't have a remote turn on feature, you can connect the REM pole to external switch for positive +12V ON/OFF.

\* To help minimize interference, it is best to run the power cables along the opposite side from the audio cables.

**Caution:** The power cables must be connected tightly. A loose connection may cause malfunctions or interference noise or distortion.

## 2 CHANNEL AMPLIFIER – FEATURES

PB715X/PB915X/PB2415X

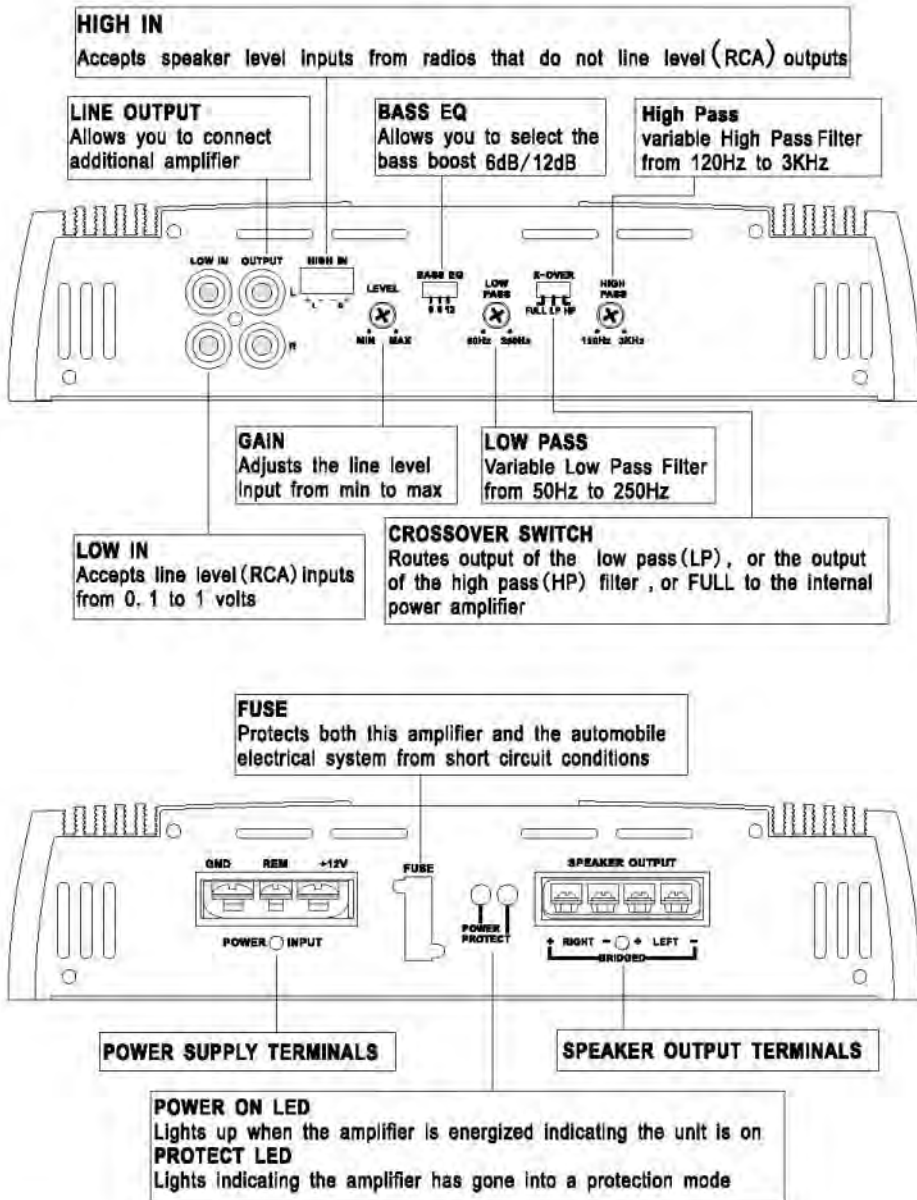

## 4 CHANNEL AMPLIFIER – APPLICATIONS

PB615X/PB1615X

### 4-CHANNEL MODE

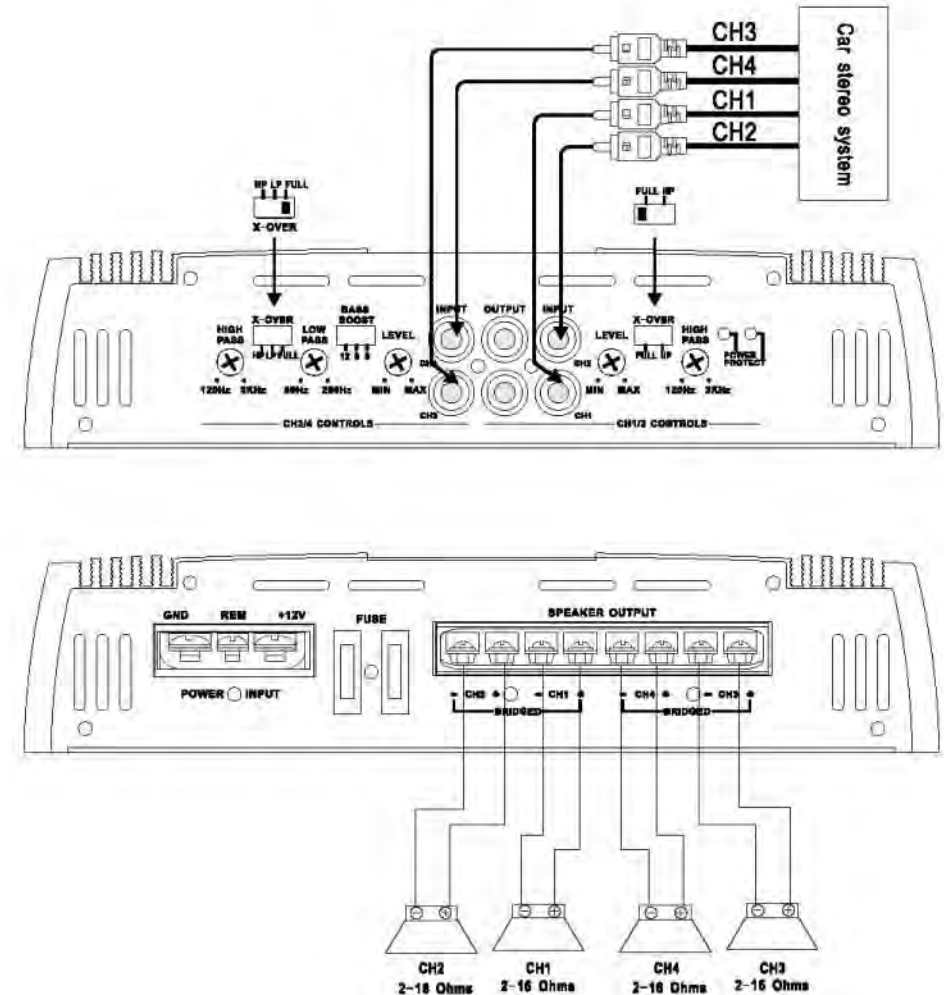

## 4 CHANNEL AMPLIFIER – APPLICATIONS

### INPUT CONNECTIONS

\* This amplifier has RCA connections for low level inputs. Low level signal is carried through RCA cables. It is preferred to use low level inputs to the amplifier if the head unit is equipped with the low level outputs.

### SPEAKER OUTPUT CONNECTIONS

You do not need to make any adjustment for the input connection of amplifier before you connect the speaker output.

\* Connect right and left speaker wire to corresponding speaker output terminals of the amplifier.

\* Be sure to have the positive wire from the speaker to the positive speaker terminal of the amplifier and the negative wire from the speaker must connect with the speaker terminal of the amplifier. Reversing any of these connections will result in the speaker cones moving out of phase which causes bass cancellation.

### LEVEL CONTROLS

Turn the VOLUME control on the amplifier to Min initially. Once the initial power sequence has been performed, set the CD/RADIO volume control to roughly 80% of full. Insert a CD or tune to a radio station and slowly turn up the amplifier VOLUME control until you hear some distortion, and then back it off for clean sound.

## 4 CHANNEL AMPLIFIER – FEATURES

PB615X/PB1615X

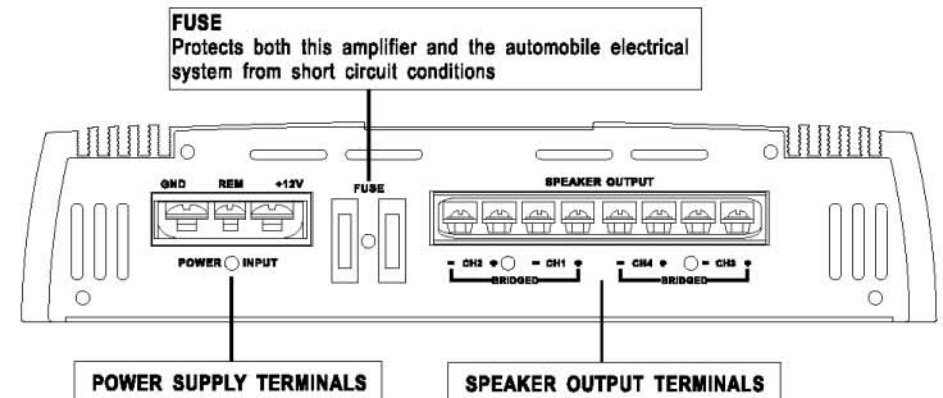
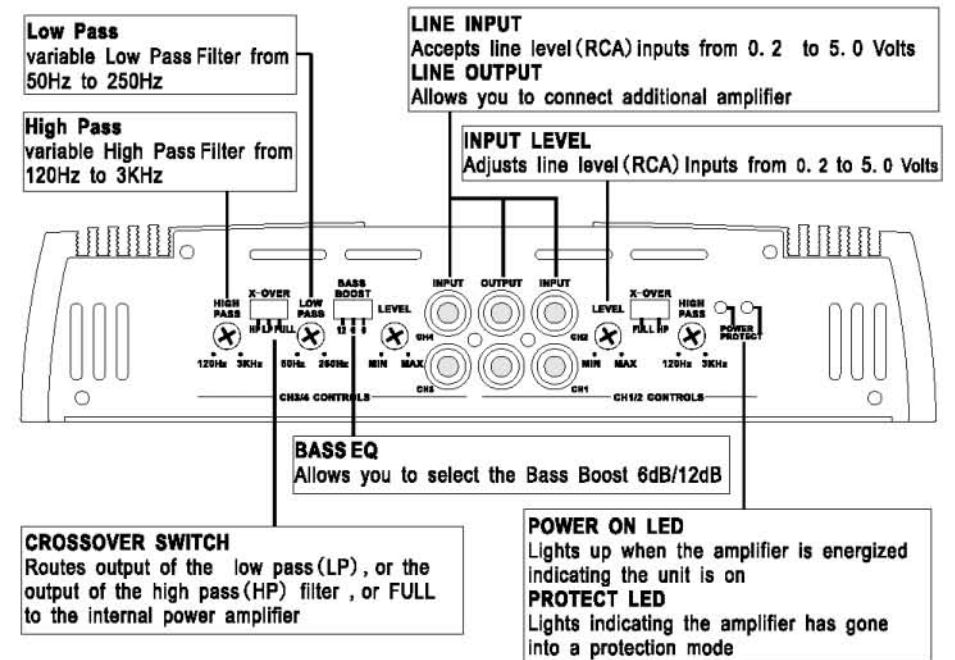

## 2 CHANNEL AMPLIFIER – APPLICATIONS

### INPUT CONNECTIONS

\* This amplifier has RCA connections for low level inputs. Low level signal is carried through RCA cables. It is preferred to use low level inputs to the amplifier if the head unit is equipped with the low level outputs.

\* This amplifier has high input connection. High level input is used from radios that do not have line-level outputs.

\* **Be sure not to use both low and high level inputs simultaneously!**

### SPEAKER OUTPUT CONNECTIONS

You do not need to make any adjustment for the input connection of amplifier before you connect the speaker output.

\* Connect right and left speaker wire to corresponding speaker output terminals of the amplifier.

\* Be sure to have the positive wire from the speaker to the positive speaker terminal of the amplifier and the negative wire from the speaker must connect with the speaker terminal of the amplifier. Reversing any of these connections will result in the speaker cones moving out of phase which causes bass cancellation.

### LEVEL CONTROLS

Turn the VOLUME control on the amplifier to Min initially.

Once the initial power sequence has been performed, set the CD/RADIO volume control to roughly 80% of full. Insert a CD or tune to a radio station and slowly turn up the amplifier VOLUME control until you hear some distortion, and then back it off for clean sound.

## 2 CHANNEL AMPLIFIER – APPLICATIONS

PB715X/PB915X/PB2415X

