

CORVETTE

PROCHARGER[®]
SUPERCHARGER SYSTEMS

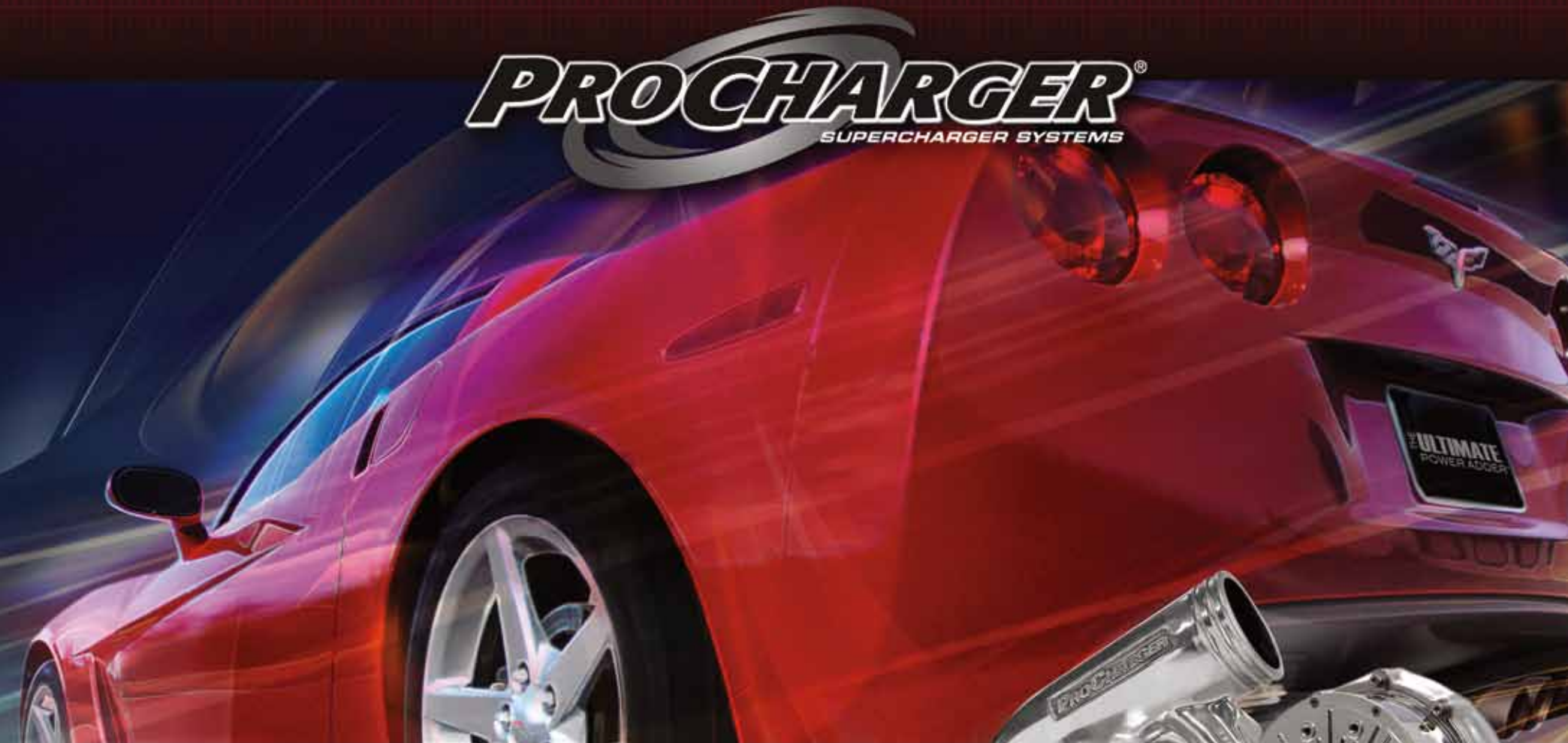

ProCharger[®] Intercooled Supercharger Systems For
CORVETTE[®] C6, C5, C4

Table of Contents

The ProCharger Advantage	3
ProCharger Systems	
LS7	11
LS3	13
LS2	15
LS6	17
LS1	19
LT1/L98	21
Tuner Kits and Transplants	23
Real World Power	25
Word On The Street.....	27
On The Road	29
At The Track	31
Centrifugal Advantage	33
Supercharger Technology	35
The Air-To-Air Advantage.....	37
Intercooling: Integrated Solution	39
Thermal Advantage	41
The Ultimate Power Adder.....	43
Design & Manufacturing	45
Proven Leadership.....	47
ProCharger: For What Moves You.....	49





The ProCharger Advantage

Proven to Produce the Largest Power Gains, Coolest Charge Air Temperatures and Greatest Air Flow

From Bowling Green to Daytona to the Pacific Coast Highway and everywhere in between, the Corvette is the only true American sports car. And what is even more American? The answer for many Corvette enthusiasts is more power! The true American sports car deserves a true American power-adder: ProCharger.

An Intercooled ProCharger Supercharger System is the power adder of choice for discriminating Corvette owners who are looking to add even more power and performance to their Corvettes.

With ProCharger's advanced technology and 15+ years of supercharging expertise, adding big horsepower to your Corvette is easier than you may think. ProCharger supercharger systems utilize exclusive features and proven technology to deliver reliable 40 - 85% emissions-legal power gains while still running high-quality pump gas.

ProCharger Supercharger System Advantages

ProCharger specializes in high-efficiency, patented and proven centrifugal supercharger technology – nothing else. So when it comes to finding a supercharger system for your Corvette, ProCharger and your ProCharger dealer are your ultimate solution for virtually any engine combination. ProCharger offers more supercharger, drive system, intercooler, bypass valve and fuel system upgrades than anyone. When

it comes to supercharger systems for your car, truck, SUV, V-twin motorcycle, UTV or boat, no one meets your needs better.

Powerful

Regardless of the model or generation of Corvette you own, a ProCharger Intercooled Supercharger System can add 40 to 75% more power to your car with no additional engine modifications. Mild to wild, regardless of your horsepower goals and aspirations, ProCharger can help you attain them.

Easy to Own – Easy to Drive

With millions of boost-enhanced miles under their tires, ProCharged Corvette owners enjoy the best of all worlds: everyday reliability and driveability combined with incredible power that is just a toe-tip away. Owning and driving a ProCharged Corvette is an exercise in simplicity. With the patented and proven, self-contained ProCharger supercharger design and simple but effective air-to-air intercooling, there is no need for special fuels, additional modifications or extended cool-down times. In fact, ProCharger systems have been painstakingly designed to be installed on completely stock Corvettes – no additional modifications required. And yes, your Corvette can be returned to stock condition without having to purchase OEM parts or components.

Stock LS7, ProCharger P-1SC-1, 5 psi,
Intercooled, 592 RWHP



Advantage: Power

Bolt on the Largest Street-Legal Power Gains in the Industry

ProCharger Corvette systems are 100 percent complete – nothing else to purchase. Corvette supercharger systems feature a standard, high-quality polished finish and come with all the components needed for an attractive, OEM-quality installation. ProCharger's system engineers went to great lengths to make the system appear as close to original equipment as possible. Another benefit of this diligently designed system is its ease of installation – install it yourself or have your ProCharger dealer install it for you. The choice is yours.

ProCharger: The ULTIMATE Power Adder®

While talk is cheap, enthusiast and racing events around the world allow ProCharger customers to prove how well our supercharger systems perform in the real world. With unmatched street performance on pump gas, far more national racing championships than all our competition combined and multiple wins in events such as HOT ROD® Drag Week, Pump Gas Drags and even the Car Craft Street Machine of the Year, ProCharger customers continue to prove that ProCharger is the Ultimate Power Adder.

ProCharger is also the only company that offers intercooled supercharger systems for C6, C5 and C4 Corvettes.

On the track and on the street, it's these factors – and many more – that separate ProCharger from all the others. ProCharger pioneered intercooling and self-contained oiling, among other innovations and continues to lead the way. For maximum power, reliability and driveability, look to ProCharger: The Intercooled Supercharging Experts®

Power-to-Weight Ratio

VEHICLE	POWER (HP)	WEIGHT (LBS)	P/W RATIO
ProCharged 2008 LS7 Z06 Corvette	714	3280	0.22
2009 ZR1 Corvette	638	3324	0.19
2008 Porsche Carrera GT	605	3042	0.19
ProCharged 2008 LS3 Corvette	609	3317	0.18
2008 Viper SRT10	600	3440	0.17
2006 Ford GT	550	3350	0.16
2008 Mercedes SLR McLaren	617	3860	0.16
2008 LS7 Z06 Corvette	505	3180	0.16
2008 Ferrari F430	490	3196	0.15
2008 Porsche 911 Turbo	480	3572	0.13
2008 LS3 Corvette	430	3217	0.13



Stock LS3, ProCharger P-1SC-1,
Intercooled, 6 psi, 538 RWHP



Advantage: Leadership

Add 175 to 250+ Horsepower to Otherwise Stock Corvette Engines

Leadership Through Innovation

Lead, follow or get out of the way. Everyone likes to use this saying as a way to differentiate themselves from the competition. But, there is a real difference when it comes to backing up those words with cutting-edge innovation, state-of-the-art engineering, superior manufacturing and unsurpassed product performance.

ProCharger was the first centrifugal supercharger manufacturer to develop complete intercooled systems for LS-powered Corvettes, years before others. Today, with the broadest LS product offering and longest track record, ProCharger is still the undisputed leader when it comes to LS-engine supercharger solutions.

Engine-Friendly Boost

With ongoing advancements in fuel injection and electronic engine management systems, intercooled centrifugal supercharging has proven to be the most engine friendly and easily installed type of forced air induction. No internal engine modifications, no special fuels – just incredible power gains from a ProCharger system and ultimate engine reliability. This gives you peace of mind from the most respected name in the aftermarket supercharging industry.

Retain Your Stock Hood

Another advantage to the highly efficient and well designed ProCharger system is the ability to retain your Corvette's stock hood. Because of the ProCharger mounting location, there is no need to purchase, prep and paint an aftermarket hood as there is with some other Corvette supercharger systems. In fact, once the ProCharger system has been installed, the car still appears "stock".

There's also no need to tap into your engine's oil system for supercharger or turbocharger lubrication, nor do you have to replace your factory exhaust system or headers.

Fuel-Mileage Friendly

Beyond overall power and performance, centrifugal forced induction is also the most fuel efficient form of high performance. Rising fuel costs and CAFE restrictions have prompted performance enthusiasts to think about fuel economy along with horsepower. It's no secret that ProCharger systems not only produce the big power numbers we all crave, but under normal operating conditions, owners report very little effect on fuel mileage and in some cases, have actually seen improved fuel economy.

Total Power

720

640

560

480

400

320

240

160

Modified LS1, ProCharger F-1A,
Twin Intercooled, 15 psi, 719 RWHP



3615 4170 4280 4725 5280 5835 6390 6945 7500

Engine RPM

Advantage: Best In Class R & D

Engineered and Designed In-House for Maximum Real-World Performance

From The Factory Performance

ProCharger believes that R&D, not to mention complete system design and component sourcing, isn't something you "farm out" or purchase from a third-party. All ProCharger systems are engineered in-house and then field-tested by a dedicated team of engineers and technicians on the largest fleet of test vehicles in the industry.

ProCharger takes pride in the fact that all Corvette supercharger systems feature a "from the factory" look and can be installed with a minimum of factory component relocation and little to no modification of stock components. The results are stunning - supercharger systems with outstanding performance, reliability and original equipment looks.

Resources, Experience and Service Excellence

All ProCharger supercharger systems are engineered in-house and then field-tested by a dedicated team of engineers and technicians on the largest R&D fleet of vehicles in the industry. ProCharger systems are tested and evaluated extensively; on the engine dyno, chassis dyno, on the street and at the track. This diligence results in the most advanced, engine-safe and durable supercharger systems on the market. Combined with world-class engineering, manufacturing, technical and customer service teams, along with unmatched power, performance and reliability – as well as a 16 plus year history of record setting performance – the choice is clear: ProCharger.



The ProCharger Campus

Made in the USA: From concept to finished product, all ProCharger supercharger systems are designed, tested and manufactured inside these state-of-the-art facilities. After enlarging the original building in 2004, the company expanded into Building 2 (at right) in 2010.

ProCharger's in-house development results in an integrated system approach in bringing the most powerful and OEM-like supercharger systems to market. The results: the most effective and reliable supercharger systems as proven by ProCharger producing more power with less boost.

PROCHARGER
RACING

SUPERCHARGER SYSTEMS • ACCESSIBLE TECHNOLOGIES, INC.

Best Dealer Network

ProCharger has the largest network of independent dealers across North America and around the world that specialize in installing and fine-tuning the supercharger system on your specific Corvette. And just like the supercharger systems they install, ProCharger dealers are the best in the business when it comes to helping you realize your performance goals and aspirations.

LS7

2006 - 2010 MODEL YEARS



The ProCharger High Output (HO) Intercooled Supercharger System for LS7 Z06 Corvettes produces 700+ crankshaft horsepower on stock engines running high quality pump gas. This system includes the industry standard P-1SC-1 ProCharger with patented, self-contained oiling and billet impeller, a highly effective air-to-air intercooler system, OEM quality brackets and installation hardware. A polished finish is standard on the supercharger and brackets.

The front fascia design for C6 Corvettes allows the use of a single, center mounted air-to-air intercooler. When coupled with the high flowing, durable and extremely efficient ProCharger, this air-to-air intercooler substantially improves overall performance and engine reliability.

An optional 3-year supercharger warranty is available as is a helical gearset option for reduced supercharger noise levels.

700+ HP

SUPERCHARGER	BOOST LEVEL	HP GAIN	INTERCOOLER
P-1SC-1	4.5 PSI	40%+	C6 3 CORE

Dealers can safely custom tune for higher power gains on stock engines.
Tuner Kits, D-1SC and F-1A with higher boost levels are available for modified engines.



“If you have the means, the skill, and the nerve, a ProCharged [LS7] Z06 will take you to your own speed limit and beyond - in a heartbeat.”

—Vette Magazine

LS3

2008 - 2010 MODEL YEARS

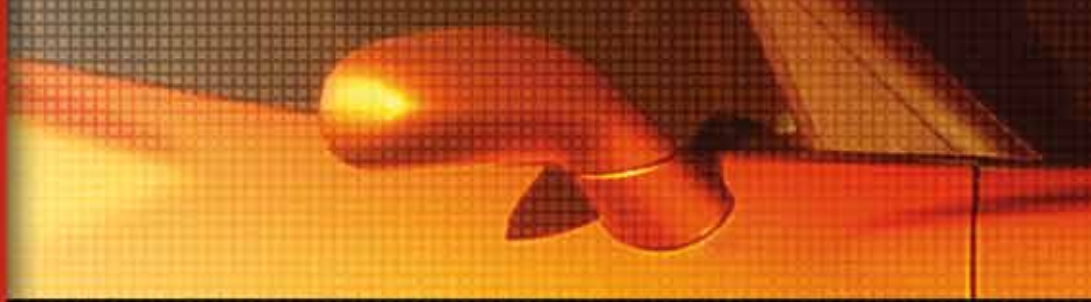

The ProCharger Intercooled Supercharger System for LS3 Corvettes offers OEM appearance, fit and finish, and delivers industry leading performance and durability. The LS3 system produces a 45%+ hp gain with just 6 psi of intercooled boost. Higher boost and power levels are available for modified engines. The front fascia design on the C6 Corvette allows for the use of a single, center-mounted, air-to-air intercooler system. When coupled with the high-flowing, durable and extremely efficient ProCharger, the intercooler substantially improves overall performance and engine reliability. With a P-1SC-1 self-contained head unit and highly effective intercooler, the LS3 system continues the legacy of ProCharger's industry leading LS1, LS2, LS6 and LS7 supercharger systems.

An optional 3-year supercharger warranty is available as is a helical gearset option for reduced supercharger noise levels.

620+ HP

SUPERCHARGER	BOOST LEVEL	HP GAIN	INTERCOOLER
P-1SC-1	6 PSI	45%+	C6 3 CORE

Dealers can safely custom tune for higher power gains on stock engines.
Tuner Kits, D-1SC and F-1A with higher boost levels are available for modified engines.



“ProCharger’s LS3 blower kit makes ZR1 power numbers – without the ZR1 price tag.”

—Vette Magazine



LS2

2005 - 2007 MODEL YEARS

The High Output (HO) Intercooled ProCharger Supercharger System for LS2 Corvettes provides the coolest charge air temperatures and lowest parasitic load in the industry. Producing more than 600 hp on otherwise stock LS2 engines with just 6 psi of intercooled boost, the ProCharger LS2 HO Intercooled Supercharger System is 100% complete, 50-state legal (EO D-365-6), and features a polished supercharger and brackets as standard equipment.

ProCharger's intercooler design for LS2 equipped C6 Corvettes allows the use of a single, center mounted air-to-air intercooler. When coupled with the high flowing, durable and extremely effective ProCharger, this intercooler substantially improves overall performance and engine reliability, producing 50-state legal, 600+ hp. An optional 3-year supercharger warranty is available as is a helical gearset option for reduced supercharger noise levels..

600+ HP

SUPERCHARGER	BOOST LEVEL	HP GAIN	INTERCOOLER
P-1SC-1	6 PSI	45%+	C6 3 CORE

**Dealers can safely custom tune for higher power gains on stock engines.
Tuner Kits, D-1SC and F-1A with higher boost levels are available for modified engines.**



“The [ProCharger] system is designed to provide maximum reliable power gains on a totally stock engine.”

—GM High Tech Performance

LS6

2001 - 2004 MODEL YEARS

Proven to produce the coolest charge air temperatures, greatest air flow, and largest power gains, the intercooled ProCharger LS6 system substantially raises the performance bar for C5 Z06 owners. Starting with an incredibly efficient P-1SC-1 supercharger, the LS6 system utilizes a large, highly effective Twin Highflow intercooler system and a high flow air inlet system. The rugged and proven bracket design shows more of the supercharger for better appearance while still providing for maximum belt wrap; this design also allows the belt to be replaced without removing the supercharger. And unlike others, not only is all the hardware of OEM quality, the entire system can be installed without having to cut any stock components.

An optional 3-year supercharger warranty is available as is a helical gearset option for reduced supercharger noise levels.

600+ HP

SUPERCHARGER	BOOST LEVEL	HP GAIN	INTERCOOLER
P-1SC-1	6 PSI	50%+	TWIN HIGHFLOW

Dealers can safely custom tune for higher power gains on stock engines.
Tuner Kits, D-1SC and F-1A with higher boost levels are available for modified engines.



“ProCharger was the first gear driven centrifugal blower with self-lubrication. That way you don’t have to tap into your engine’s oil system. Whether it’s for the street or the strip, a supercharger is going to make more power, more safely with an intercooler.”

—Horsepower TV

LS1

1997 - 2004 MODEL YEARS



An outstanding performance package from the factory, LS1 Corvettes are even better with the addition of a powerful and proven ProCharger supercharger system. ProCharger introduced a complete supercharger system for LS1-powered Corvettes a full two years before others. The HO System set the standard and has now evolved into the industry leading Stage II Intercooled System. Sharing much of its design with the LS6 system, including the industry-standard P-1SC-1 ProCharger, highly effective Twin Highflow intercooler system with a high-flow air inlet design, the ProCharger LS1 system truly represents the pinnacle of incredible power gains that you can enjoy day after day.

An optional 3-year supercharger warranty is available as is a helical gearset option for reduced supercharger noise levels.

520+ HP

SUPERCHARGER	BOOST LEVEL	HP GAIN	INTERCOOLER
P-1SC-1	7 PSI	55%+	TWIN HIGHFLOW

Dealers can safely custom tune for higher power gains on stock engines.
Tuner Kits, D-1SC and F-1A with higher boost levels are available for modified engines.



“Just one romp of the throttle from a standstill, it becomes quite clear that the centrifugal blower is every bit the equal of a roots blower when it comes to low-end grunt” [and greater efficiency, more power at higher RPM]

—Popular Hot Rodding

LT1

**1992 - 1996 MODEL YEARS
OFFERING ALSO INCLUDES 1996 LT4**

When GM introduced the "new generation" of small block engines with the LT1, the foundation was laid for an entire family of supercharging-friendly Corvette engines. The ProCharger HO Intercooled Supercharger Systems for LT1 engines allow C4 Corvette owners to reap the benefits of bolting on 55-60 percent power gains without having to modify their engines.

Working as a system, the front-mounted intercooler, high-flow air intake system and ultra-efficient ProCharger supercharger provides safe, reliable and enjoyable horsepower gains while still retaining the C4's stock hood and exterior appearance. ProCharger is also the only company that offers inter-cooled supercharger systems for C4, C5 and C6 Corvettes.

An optional 3-year supercharger warranty is available as is a helical gearset option for reduced supercharger noise levels.

450+ HP

SUPERCHARGER	BOOST LEVEL	HP GAIN	INTERCOOLER
P-1SC	8 PSI	55 - 60%	2 CORE

**Dealers can safely custom tune for higher power gains on stock engines.
Tuner Kits and D-1SC with higher boost levels are available for modified engines.**



L98

1985 - 1991 MODEL YEARS

375+ HP

P600B or D-1 SUPERCHARGER

Call for more information



Tuner Kits and Transplants

While all ProCharger Corvette supercharger systems are available as 100 percent complete for stock vehicles, we recognize the fact that some Corvette owners are looking to add the awesome power and reliability of a ProCharger to their modified or “built” engine combinations. That’s where a ProCharger tuner kit comes in.

ProCharger tuner kits exclude fuel components and computer tuning solutions, but otherwise, are identical to our complete systems. These kits are intended to be tuned by professional tuners or dealers specializing in tuning supercharged engines. Tuner Kits are also used on stock engines when a dealer will be supplying the fuel system and custom tuning.

Custom 1967 Corvette with a ProCharged LS1

Corvette Transplants

Classic looks with modern ProCharger power, what could be better than that? ProCharger and our installing dealers recognize the popularity of “transplanting” newer, EFI-equipped engines into older model Corvettes, especially when using the boost-friendly GM LS engines.

Several knowledgeable ProCharger dealers across the country have already demonstrated the feasibility of incorporating a ProCharger supercharger and intercooler into their resto-mod and custom transplant creations.

Given their compact dimensions and snug mounting locations, a ProCharger supercharger may be the crown jewel for your own custom Corvette transplant.

If you want to make your LS transplant stand above the rest – both in performance and visual impact, ProCharger and our Corvette-specialized dealers would love to help you reach your high performance goals.





Real World Power

Bolt on the Largest Street-Legal Power Gains in the Industry

ProCharger-Power to the People

What good is power if you don't get to enjoy it? The beauty of a ProCharger-equipped Corvette is that once the system is installed, owners still get to enjoy the renowned handling and braking performance the Corvette is famous for, but with the additional power and acceleration performance they crave. A ProCharged Corvette is a vehicle you will want to drive as much as you possibly can – all while being rewarded with incredible real-world power, pump gas convenience and outstanding driveability and reliability.

ProCharger has been providing supercharger solutions for LS Corvette owners far longer than any other aftermarket power adder company. So when it comes to putting power on the street or track, no one does it better than ProCharger owners. From stock-appearing Corvettes, to completely "built" show and race cars, Corvette owners from around North America and the world are enjoying the awesome power, performance and everyday driveability of their ProCharged Corvettes.

Modified LS Engines and ProCharger

ProCharger was the first supercharger manufacturer to take LS-powered Corvettes into the 500, 600, 700, 800, 900 and 1,000+ horse-

power ranges. And yes, these cars are still being driven on the street by their power hungry owners. Beyond leadership on stock Corvettes, ProCharger absolutely dominates when used on modified LS engines.

To see even more examples of distinguished ProCharged Corvettes, check out the Owners Gallery at ProCharger.com.



**Stock LS7, ProCharger P-1SC-1,
Intercooled, 639 RWHP**



LS2, ProCharger F-1C, 8-rib Drive System, 16.5 psi, 905 RWHP



LS6, ProCharger D-1SC, 752 RWHP, 9.50 ET @ 146 MPH

Word On The Street

“Due to superior efficiency, centrifugal superchargers heat the air less than roots blowers per pound of boost, thus each pound carries more oxygen molecules (something we refer to as greater mass flow). ... [This means] **a centrifugal supercharger is capable of supplying more power per pound of boost than a roots blower.**”

—*Super Chevy*

“The ProCharger is a brute of a compressor, creating more boost pressure than any other centrifugal supercharger on the market. But the real beauty of the system is the fact that it is **designed from the ground up as an intercooled system.**”

—*Corvette Fever*

“So the kit installs cleanly and uses proven technology, but how does it perform? Equipped with a modest 6 psi pulley, our test car’s output jumped from a preternaturally healthy 373 hp in stock form to a downright spooky 523. Allowing for a 15 percent loss through the Vette’s six speed manual drivetrain, we can estimate that the ProCharged C6 [stock LS2] is spinning up just over 615 horses at the flywheel.”

“Cleanly packaged and gleaming in the midday sun, **the finished installation looks as if it might have been performed on the line at Bowling Green.**”

—*Vette Magazine*

“We ran the car on the dyno and were pleasantly treated to 644 [rw]hp at 5,700 rpm, with 609 lb-ft of torque at 5,000 rpm. With the system completed, it’s hard to tell the power potential that resides under the covers. **The system looks great and performs even better.**”

—*Corvette Fever*

“So far the Devil Ray has touched 220 mph”

“When you blast past a Lamborghini like it was standing still, there’s great satisfaction to be had in knowing that you did it effortlessly and for significantly less money.”

“Readings of 715 rwHP at 5,800 rpm and 690 lb-ft at 5,000 rpm don’t tell the tale of what a beast the ProCharged 427 really is. With a torque curve that exceeds 500 lb-ft below 3,000 rpm and averages over 600 lb-ft to redline, **this motor is a torque monster par excellence.**”

—*Vette Magazine*

“**ProCharger is the world headquarters of supercharging.**”

—*Bret Kepner, ESPN2*

“Until you go to wide open throttle—and then the raging beast takes over in a rush of sound and fury that’s all the more impressive out of a mild-mannered, silver convertible. I like it, a lot! **This is definitely an instance where a manufacturer’s claims are not just so much hot air.**”

—*Vette Magazine*



“The day before the installation, our otherwise-stock test subject [2007 Z06] laid down an impressive 459.80 hp and 430.07 lb-ft of torque on the same dyno, making it the most potent C6 Z06 we’ve tested to date. Those numbers paled in comparison with the **ProCharged readings, however, which came in at a jaw-slackening 583.18/511.92.** Applying a conservative 15 percent correction factor for driveline losses yields crankshaft figures of **711 horses and 624 l-ft**, more than enough to depose the “King of the Hill” ZR1 in a dyno duel. The king is dead; long live the king.”

—*Vette Magazine*

“The Intercooled ProCharger centrifugal supercharger system.... served up an astonishing 962.6 pound-feet of torque.”

—*Motor Trend*

On The Road

Winding roads or desert highways, hitting road courses and drag strips, car shows and cruise nights – wherever Corvettes and Corvette owners gather, chances are good that a ProCharged Corvette is out front and pulling away.

A ProCharger Intercooled Supercharger System is the ideal way to make your Corvette stand out from the crowd, both in terms of performance and open hood “wow” factor.

If fuel mileage and big power are on your mind, consider this: an LS7

Z06 Corvette built by a ProCharger dealer runs a ProCharger D-1SC intercooled supercharger at 8 psi of boost, along with minor modifications. This car makes 656 rwhp and averages 32.5 highway mpg.

Another example of big Corvette horsepower with low fuel consumption was demonstrated on the HOT ROD Power Tour. A Wyoming-based owner drove his '06 Corvette with a D-1SC ProCharger feeding a modified LS2 engine. During the event, this car put down 578 rwhp and averaged 32.8 highway mpg!



What better way to hit the road than in a ProCharged Corvette?

NATIONAL
CORVETTE MUSEUM
LEFT

Look for ProCharger at top-tier Corvette events around the country, and be sure to check us out at the all-new Corvette Cafe' inside the National Corvette Museum in Bowling Green, KY.



At The Track

ProCharger Motorsports

ProCharger has a long history – 15 years now – of helping an incredible number of racers and enthusiasts accomplish their performance goals: WINNING! From drag strips to road courses, and from the salt flats of Bonneville to open road races and rear-wheel dyno competitions, more and more ProCharger owners are reaching and exceeding their performance goals in amazing fashion.

When it comes to motorsports, talk is cheap. It seems like there are always too many aftermarket manufacturers willing to inflate their performance claims. ProCharger-equipped racers and enthusiasts prefer to let their actions and results speak for themselves.

We Race, You Win

The same design philosophy that puts top racers into the winner's circle can be found in every street-legal ProCharger supercharger system. With a ProCharger system, not only will you receive the largest and most engine-friendly horsepower gains, you also have the peace of mind knowing that your supercharger was designed to reliably and consistently produce event and championship-winning power race after race, year after year.

What are your high-performance goals? Let ProCharger help you blow them away.





Consider these ProCharger Motorsports Achievements:

- In drag racing, the 80 quickest centrifugal racers are all powered by ProCharger
- HOT ROD Drag Week Championship
- HOT ROD Pump Gas Drags Championship
- Car Craft Street Machine of the Year Championship
- Good Guys Muscle Machine of the Year
- Bonneville record – World's Fastest Camaro
- Bonneville record – World's Fastest Production Mustang
- The ONLY supercharger to make 2,000 horsepower on pump gas
- The ONLY supercharger to make 3,000 horsepower on alcohol - nearly twice the power of the closest centrifugal!
- More than 50 International drag racing Championships in the past 10 years

Centrifugal Advantage

Supercharger Efficiency

By its very definition, a supercharger is a device (such as a blower or compressor) for increasing the volume air charge of an internal combustion engine over that which would normally be drawn in by the intake stroke of the pistons. Efficiency refers to both the heat created by the supercharger and the power required to drive it.

Today, there are two different types of superchargers being offered by the performance industry:

- Centrifugal superchargers
- Positive-displacement blowers

Due to their design, it's a commonly accepted engineering fact that centrifugal compressors are much more efficient than positive displacement superchargers. More efficient compressors mean more efficient supercharger systems, this in turn means more power across a wider operating range for your engine. This is the very core of the ProCharger supercharger advantage.

The advantages are in terms of airflow and air pressure, and as a result, centrifugal compressors produce greater power and significantly lower charge air temperatures. This broad operational range supports future engine modifications, meaning you are less likely to "outgrow" your ProCharger supercharger than a positive displacement design.

At higher boost levels, centrifugal superchargers remain 70 to 80% efficient, whereas positive-displacement-blowers are less efficient to begin with and efficiency further declines as pressure increases.

Positive-displacement blowers are also mounted on top of the engine where they quickly become heat soaked, further increasing charge air temperatures. Positive-displacement blowers deliver a nearly-fixed volume of air per revolution at all RPMs, making PD blowers less efficient than ProCharger centrifugal design throughout the engine's performance operating range.

Advantage In Efficiency *and* Operating Range



More Boost After Peak Torque

Most of today's stock street engines have a torque curve that falls away while horsepower is still on the rise. A ProCharger centrifugal supercharger system is able to increase the amount of intercooled boost available to your engine once it is past its peak torque output. Now, rather than your engine "going flat" after peak torque, it continues to build power right up to your engine's maximum RPM. The result is more power across the typical performance engine operating RPM range.

A ProCharger centrifugal supercharger can also support future modifications to your engine or exhaust system. Thanks to industry-leading step-up ratios and rugged design, ProCharger provides the best performance at any power level. High-flow intake manifolds, camshaft, cylinder heads and exhaust systems can all be supported via more airflow and boost from the same ProCharger supercharger with a simple pulley upgrade.



Supercharger Technology

Our industry leading engineering team utilizes the most advanced technology to ensure maximum performance from our supercharger systems. Each of our Corvette intercooled supercharger systems have been individually crafted to match your vehicle model. To ensure every facet of the installation, ProCharger systems provide all the parts you or your dealer need for a trouble-free experience.

Integrated System Design

All ProCharger systems feature matched superchargers and intercoolers to provide the coolest charge air temperatures available. Unlike others, ProCharger system design locates both the supercharger and intercooler in a fresh air stream, away from the detonation-causing and power-robbing heat of the engine.

At ProCharger, we go to great lengths and take pride in the fact

that all of our Corvette intercooled supercharger systems and kits can be installed with a minimum of factory component relocation and little to no modification of stock components. Complete Corvette LS supercharger systems include: self-contained supercharger, mounting brackets, air-to-air intercooler system, bypass system, tubing/connectors, fuel injectors, programming, hoses and hardware.

High-performance Corvette owners can take comfort in the fact that before any ProCharger system is made available, it must pass a rigorous series of performance testing hurdles, both on the dyno and on the street.

Before they ship, each and every ProCharger supercharger is tested for a variety of quality and performance measures. The result is the most durable and trouble-free supercharger in the industry.



PROCHARGER

“Even better, the new helical gears in our head unit [P-1SC-1] quelled blower whine to near-inaudible levels.”

—Vette Magazine

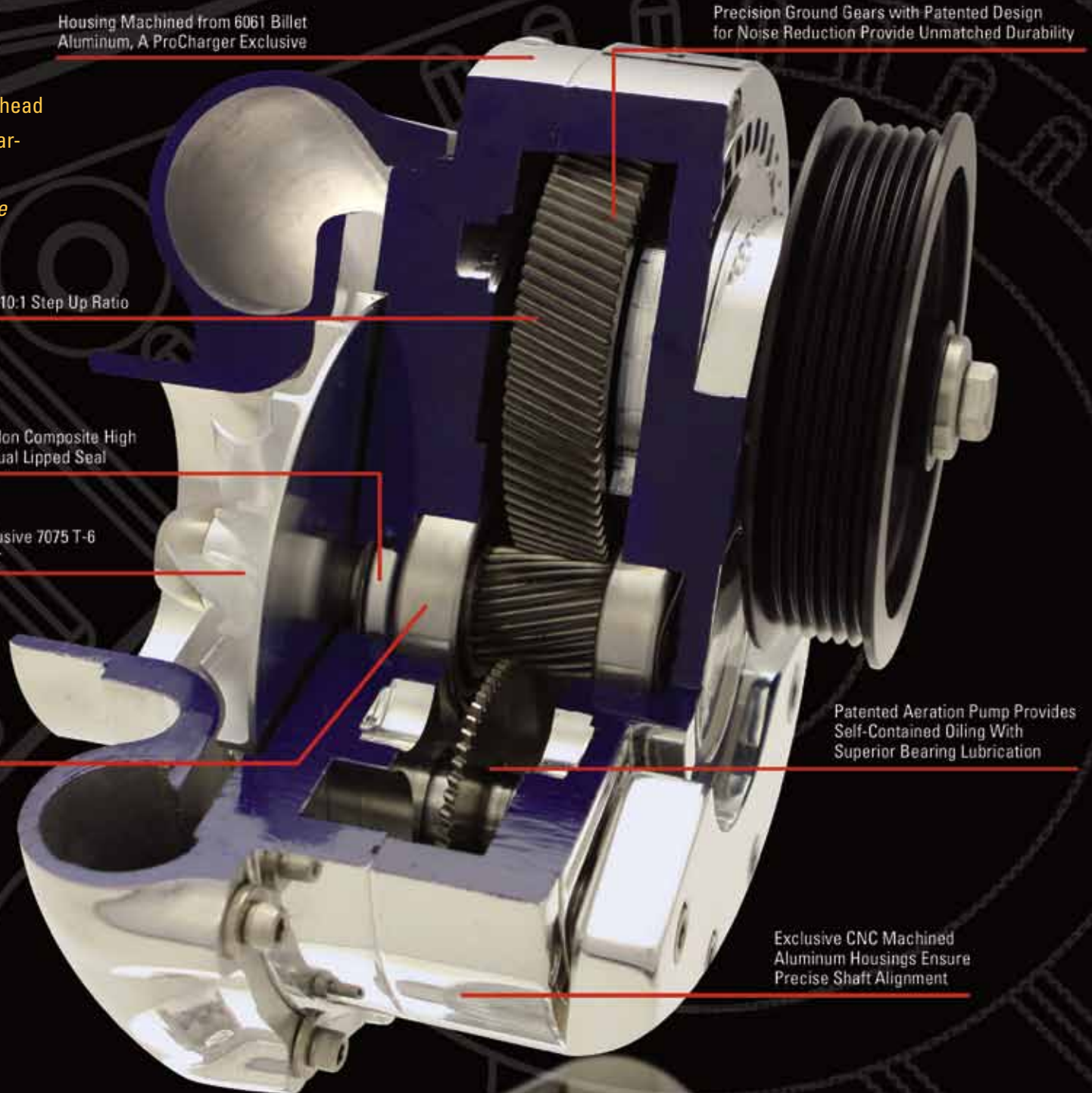

Housing Machined from 6061 Billet Aluminum, A ProCharger Exclusive

Precision Ground Gears with Patented Design for Noise Reduction Provide Unmatched Durability

Industry leading 4.10:1 Step Up Ratio

Custom Teflon Composite High Pressure Dual Lipped Seal

Industry Exclusive 7075 T-6 Billet Impeller

Super Precision High Speed Rated Aerospace Spec Support Bearings

Patented Aeration Pump Provides Self-Contained Oiling With Superior Bearing Lubrication

Exclusive CNC Machined Aluminum Housings Ensure Precise Shaft Alignment

Optional helical gearset shown

Intercooling: Integrated Solution

Intercooling Leadership, Coolest Charge Air Temperatures

ProCharger pioneered the use of air-to-air intercooling and self-contained, gear-driven supercharger oiling among other innovations. While others continue to change their story and recommendations, ProCharger continues to lead the way with the coolest charge air temperatures and largest street-legal power gains. Relentless innovation delivers consistent, real-world power advantages for countless ProCharger-equipped Corvette owners.

The Air-To-Air Intercooling Advantage

Since their earliest uses in fighter and bomber aircraft, the advantages of air-to-air intercooling have been demonstrated time and time again. It's a simple fact of physics: cooler air makes more power. Period. Today, ProCharger owners are still reaping the performance benefits of air-to-air intercooling.

On street driven vehicles, air-to-air intercooling is a natural fit because it locates the intercooler at the front of the car where it is exposed to a constant supply of cooling airflow. Consisting of large-volume air plenums, ProCharger's air-to-air intercoolers utilize a highly →

Intercooling Removes Heat

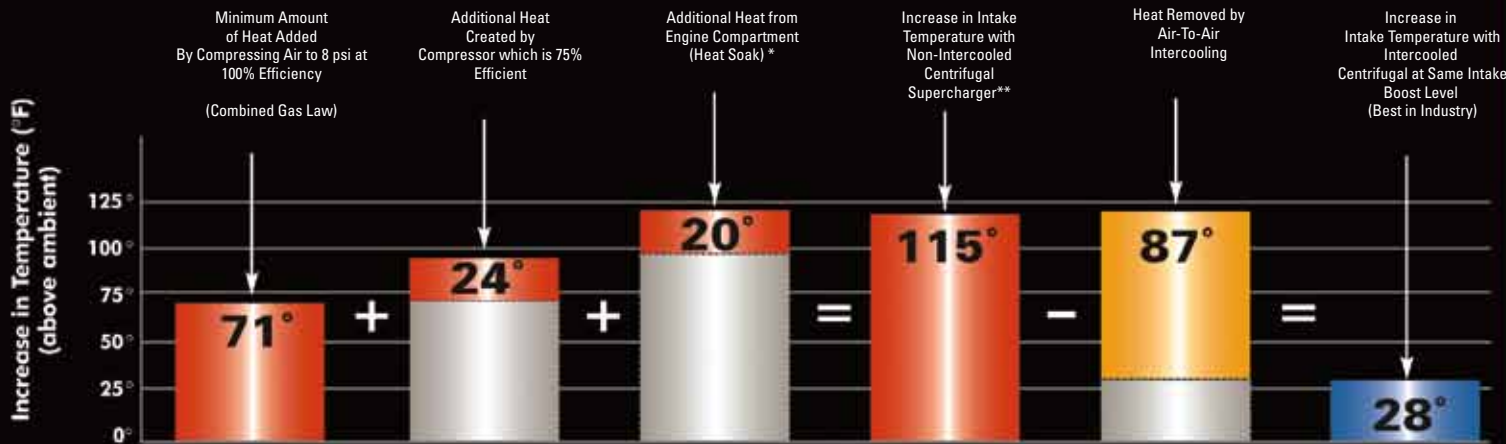

* Radiant heat from engine and exhaust transferred through air, conductive heat transferred directly and convective heat from engine oil. This engine compartment heat is not addressed by SAE J1723 (supercharger efficiency standard)

** Temperature will be higher for PD blower or turbocharger

“When space permits an adequately sized air-to-air intercooler to be fitted and given access to decent airflow, it **will always prove superior**. The only excuse for a liquid-based intercooler is when severe space restrictions exist [including positive displacement superchargers, due to mounting location] or... when an iced coolant can be used”

–“Supercharged”, Corky Bell

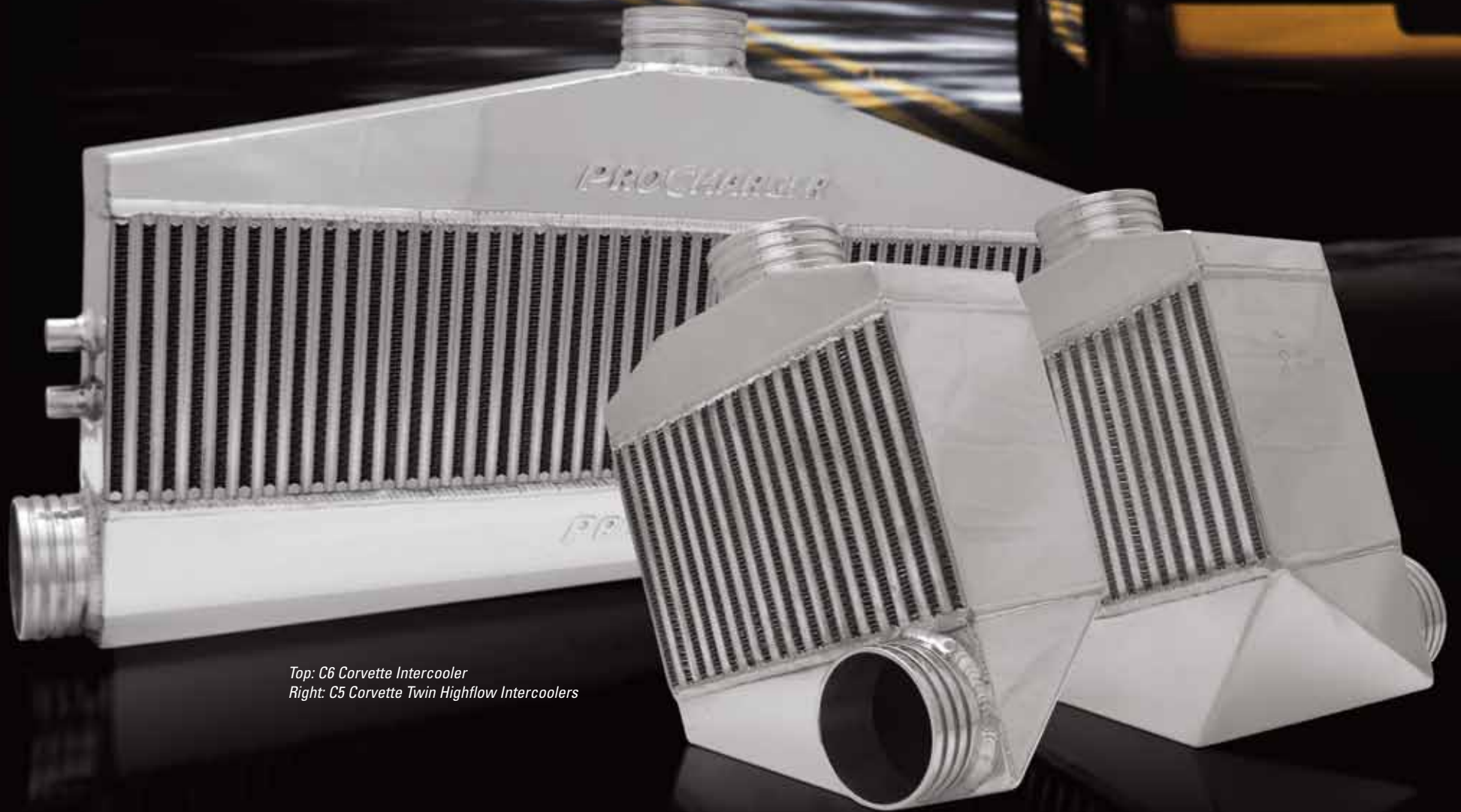

*Top: C6 Corvette Intercooler
Right: C5 Corvette Twin Highflow Intercoolers*

The Air-To-Air Advantage

efficient and durable cross-flow intercooler core that provides large surface areas for superior levels of heat dispersion.

The Fundamental Advantage

Air-to-air intercooling is a one-step process and represents a fundamental ProCharger advantage. Compressed air enters one side of the intercooler, making its way into the cross-flow core. Once in the core, the compressed air is cooled by the airflow moving through the passages or fins of the intercooler. Next, this cooler, denser air is routed into the throttle body and into the engine. In engineering

terms, air-to-air intercooling represents a one-step cooling process.

On the other hand, positive-displacement blowers are forced to use an air-to-water intercooler system which is a complex arrangement of intercooler cores, hoses, fittings, a coolant pump, electrical connections and yes, a front-mounted air-to-air heat exchanger. In street applications, an air-to-water intercooler is in fact an air-to-water-to-air system.

Typically packed into the tight and hot confines under the supercharger and intake manifold deep in the V of the engine, air-to-water-

One Step Process: Air-to Air

Air-to-air intercooling represents a one step process of cooling the compressed air before it enters the engine. Simple, easy-to-install and highly effective, ProCharger's air-to-air intercooler design provides the coolest charge air temperatures for the highest horsepower gains.

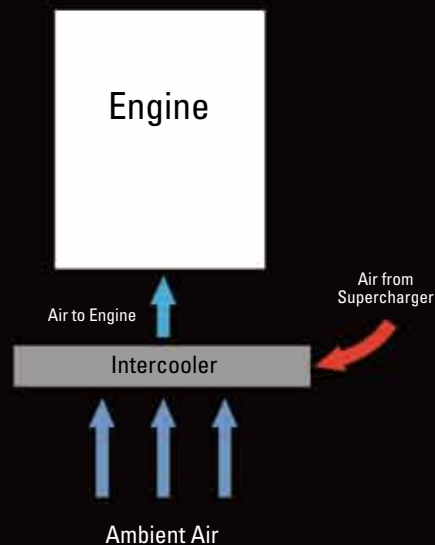

Two Step Process: Air to Water-to-Air

Air-to-water-to-air is a two-step process of cooling the compressed air before it enters the engine. Typical air-to-water-to-air intercooler systems are a complex arrangement of potentially unreliable components. Not only is this configuration less effective, it also adds complexity and risk of coolant leaks and/or coolant pump failure.

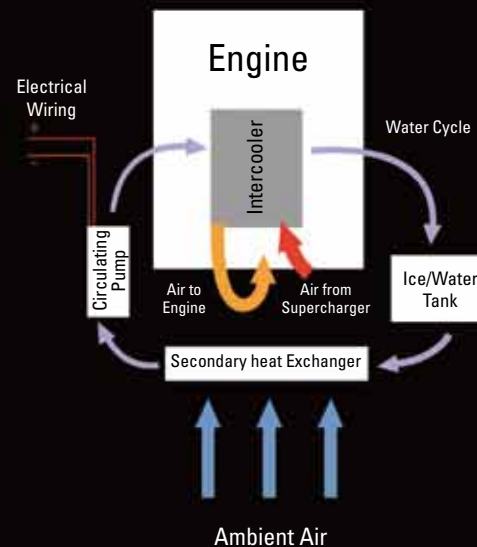

to-air intercooler systems are very complex, difficult to install, and not as effective as air-to-air intercooling. In engineering terms, air-to-water-to-air intercooling is a two-step cooling process.

Benefits Of Air-To-Air Intercooling

- More effective
- More reliable
- No maintenance
- Simpler and far easier to install
- Intercooler exposed to a constantly replenished airflow
- Large intercooler surface area for quick recovery and repeatable performance in real-world driving situations
- Superior charge air cooling capabilities

Air-to-air intercooling is effective and simple – no worries of a coolant pump failure or coolant leaks that are possible with an air-to-water-to-air intercooling system. Failure of an air-to-water-to-air intercooler can

result in serious and expensive engine damage due to detonation or water entering the engine oil or engine itself.

ProCharger's industry leading system efficiency is proven by producing more power with less boost than other superchargers while also having the ability to produce the highest boost and power levels. For maximum power, reliability and driveability since 1994, customers have looked to ProCharger: The Intercooled Supercharging Experts®.

For more information: visit procharger.com/intercooled.shtml

"The normal closed loop, air-to-water intercooler system [not using ice] is not as effective as a properly designed air-to-air intercooling system since the cooling medium or the liquid coming from the front heat exchanger is always warmer than the ambient air temperature."

—"All About Intercooling", George Spears

Optimal Intercooler Locations for Both C6 & C5



Exposing the intercooler to a constant supply of cool, incoming air is key to maximizing the heat exchange process. ProCharger systems for C6 Corvettes utilize a single, center-mounted intercooler, whereas C5 cars utilize an innovative Twin Highflow arrangement of two intercoolers.



Thermal Advantage

ProCharger Supercharger and Intercooler Location Avoids Heat Soak



ProCharger LS3 Underhood (thermal view below)

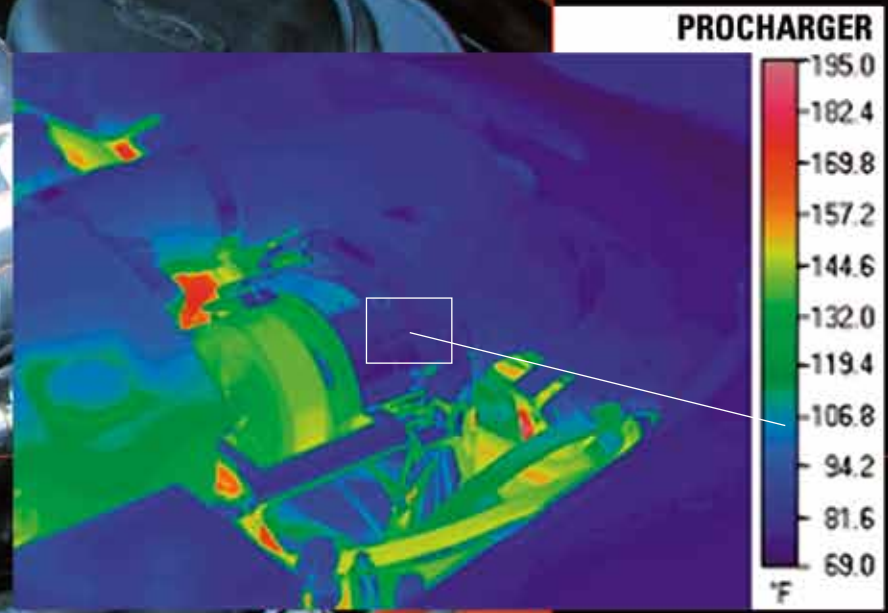

PROCHARGER

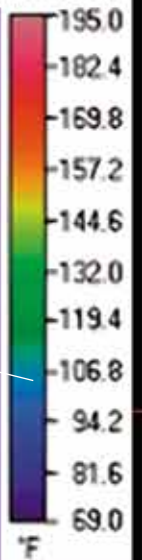

It's really quite simple: cooler air is more dense. Denser air is able to produce more power. If your goal is maximum reliable power, then you need the coolest charge air temperatures possible. When it comes to producing consistent and reliable power, heat is the enemy.

These images illustrate the thermal advantages of a ProCharger supercharger system when compared with a turbocharger and positive-displacement blower. By their very design, centrifugal superchargers are more efficient compressors and create less heat during their operation. Additionally, ProCharger superchargers and intercoolers are mounted in front of the engine, which during normal driving, is a much cooler environment than on top of the engine.

Turbochargers require hot engine exhaust to compress air. The result

is a very hot turbine and turbine housing which transfers heat to the compressor. Turbochargers also create exhaust backpressure, causing additional heat build up in exhaust manifolds (high EGT's), cylinder heads, valves and valve train components.

Positive displacement (PD) blowers are typically located directly on top of the engine or deep between the cylinder heads. Because they are attached to or surrounded by hot engine components, this is an extremely hot environment. Now add the heat created by their lower-efficiency compressors and you end up with a hot compressor producing hot, compressed air. The location of the PD blower necessitates the use of a complex air-to-water-to-air intercooler system which is also located in a hot and heat-soaked environment.

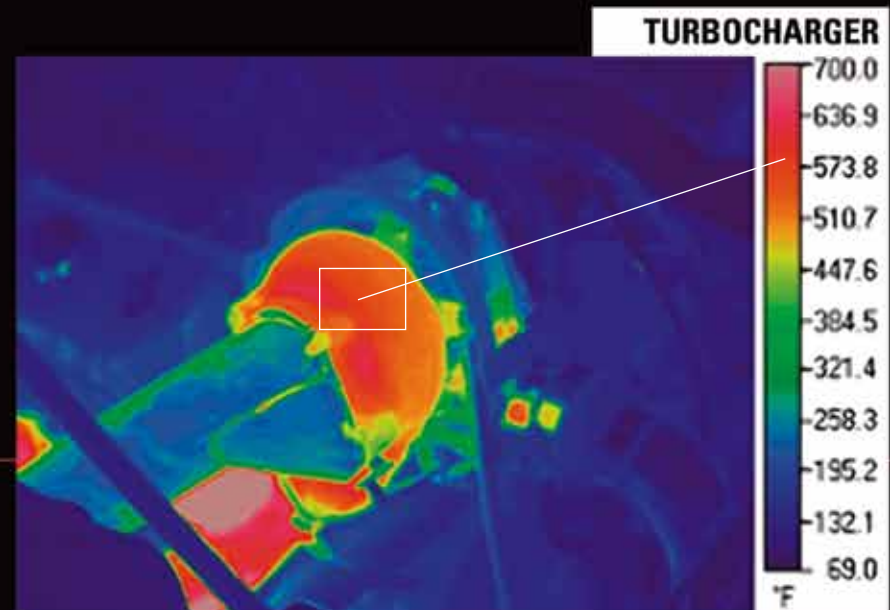
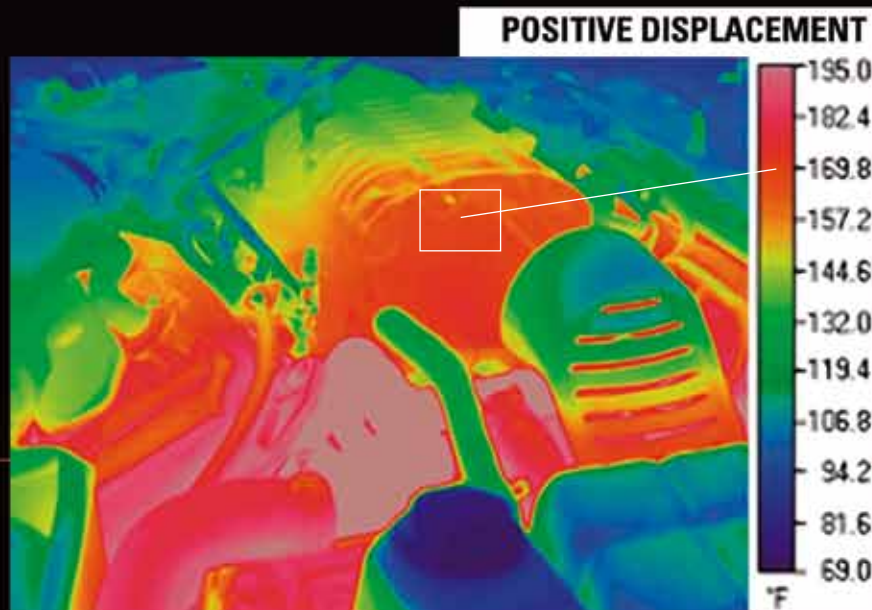

Temperature scale higher due to extreme heat produced by turbocharger

The Ultimate Power Adder®

Proven by dealers, owners and Corvette enthusiasts around the world, no other form of aftermarket power-adder provides the combination of power, reliability, ease of installation and maintenance, engine safety and cool operation of a ProCharger. Here's why.

Nitrous Oxide

Initially, nitrous may look like a bargain, but a review of the facts reveals otherwise. Nitrous oxide accelerates the combustion rate, which in turn, increases peak cylinder pressures. This combination greatly increases the probability of piston-melting pre-detonation. This rapid increase in cylinder pressure also increases the load placed

on internal engine components. Additionally, nitrous oxide adds the expense and hassle of constantly having to refill bottles and is not always available when you need it.

Positive-Displacement Blowers

Centrifugal superchargers offer substantially higher adiabatic efficiencies than their positive-displacement (PD) counterparts. PD blowers are located on top or nestled in the "V" of the engine, placing them in a very hot, harsh environment which results in significantly hotter charge air temperatures. This location also requires the use of a significantly more complex and less effective air-to-water-to-air

7.7

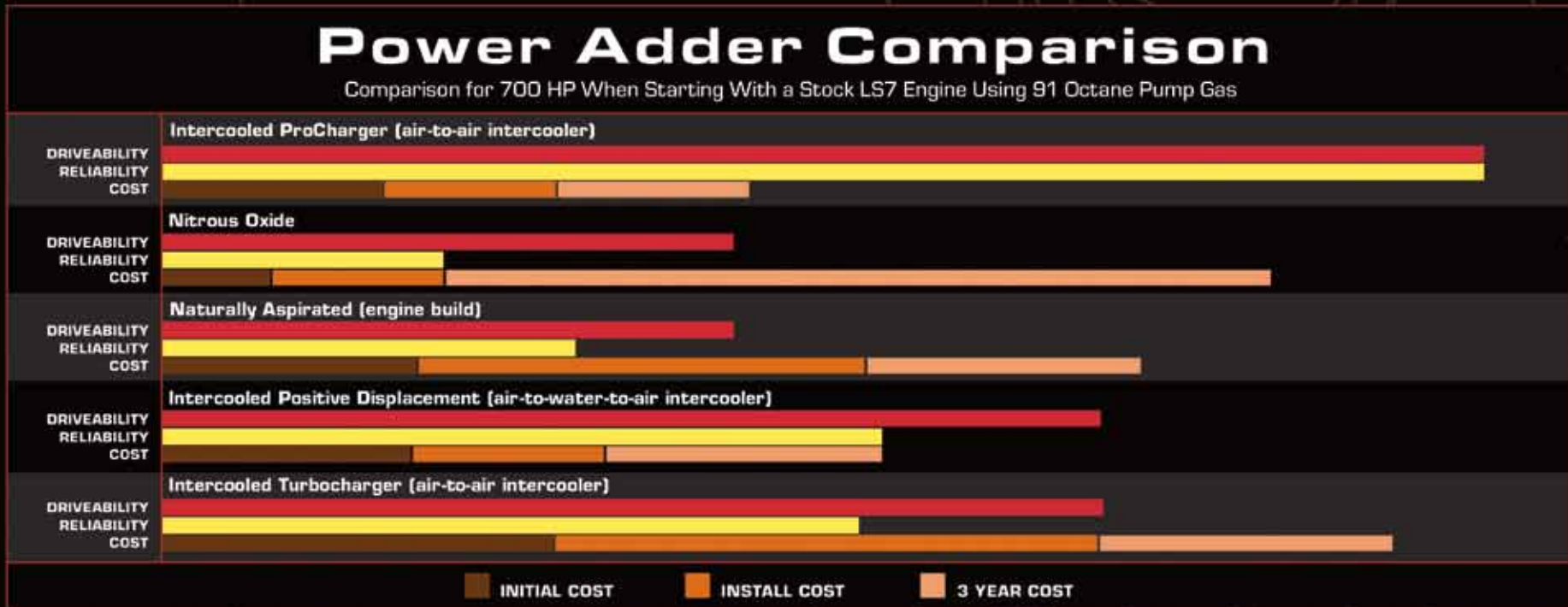

intercooling configuration. To cope with these high charge air temperatures, PD blowers must be tuned extremely rich with less timing. This reduces the vehicle's fuel efficiency, driveability, power and engine longevity.

Turbochargers

A turbocharger, or turbo, is in fact a form of supercharging as it uses a centrifugal compressor to increase the pressure of the air entering the engine. Although they use advanced compressor technologies similar to ProCharger's compressor designs, turbo systems' initial cost and complexity make them less practical for everyday street driving. Because a turbo relies on hot engine exhaust to create power, they also create high exhaust temperatures and backpressure, high charge air temperatures and are subject to "lag" that degrades their real-world driving performance. Additionally, turbos require engine oil feed and return lines for lubrication and due to extreme heat, increases the thermal breakdown of your engine's oil.

Other Centrifugal Superchargers

When compared with other centrifugal superchargers on the market, ProCharger superchargers support nearly twice the horsepower along with much greater durability and reliability. Additionally, ProCharger is focused solely on centrifugal compressor technology, providing superior product and support to customers and dealers.

Large Displacement Engines

The expenses associated with building an engine large enough to produce the same power as a ProCharged stock engine just doesn't add

up, especially when you consider the poor idle quality and extra fuel that a larger engine will consume during normal and spirited driving.

ProCharger: The ULTIMATE Power Adder[®]

When compared to other power adders for late model, EFI Corvettes, nothing comes close to a 100 percent complete, Intercooled ProCharger Supercharger System.



Design & Manufacturing

ProCharger introduced the industry's first self-contained, gear-driven supercharger in 2000. Since then, this patented and proven self-contained design has become the standard by which other centrifugal superchargers are measured.

The top selling ProCharger P-1SC, P-1SC-1 and D-1SC supercharger models share many of the design elements that deliver the record setting durability and performance of the ProCharger F-Series super-

chargers. With their rugged design, including an exclusive billet gear case, these self-contained superchargers are powerful and efficient enough to harness the benefits of air-to-air intercooling, while being durable enough to be backed by the best warranty in the industry.

The patented self-contained design eliminates the need for an external oil supply or oil lines that require a hole to be punched in the engine's oil pan. Additionally, testing has shown self-contained superchargers run cooler than those fed by hot engine oil.

Exclusive Billet Impellers

Using state-of-the-art, five-axis CNC machines, ProCharger impellers are crafted from aircraft-grade 7075 T-6 aluminum alloy for tremendous strength and performance. This top tier material allows for larger impellers that weigh less and are free of the flaws found in typical cast impellers. Large, structurally sound impellers are capable of higher speeds, which flow more air, and thus produces more power.

Internal Oil Pump

At the heart of the ProCharger self-contained design is a simple, but highly effective oil aerator. This oil aerator creates the oil mist lubrication required for the high-speed precision bearings and gears.

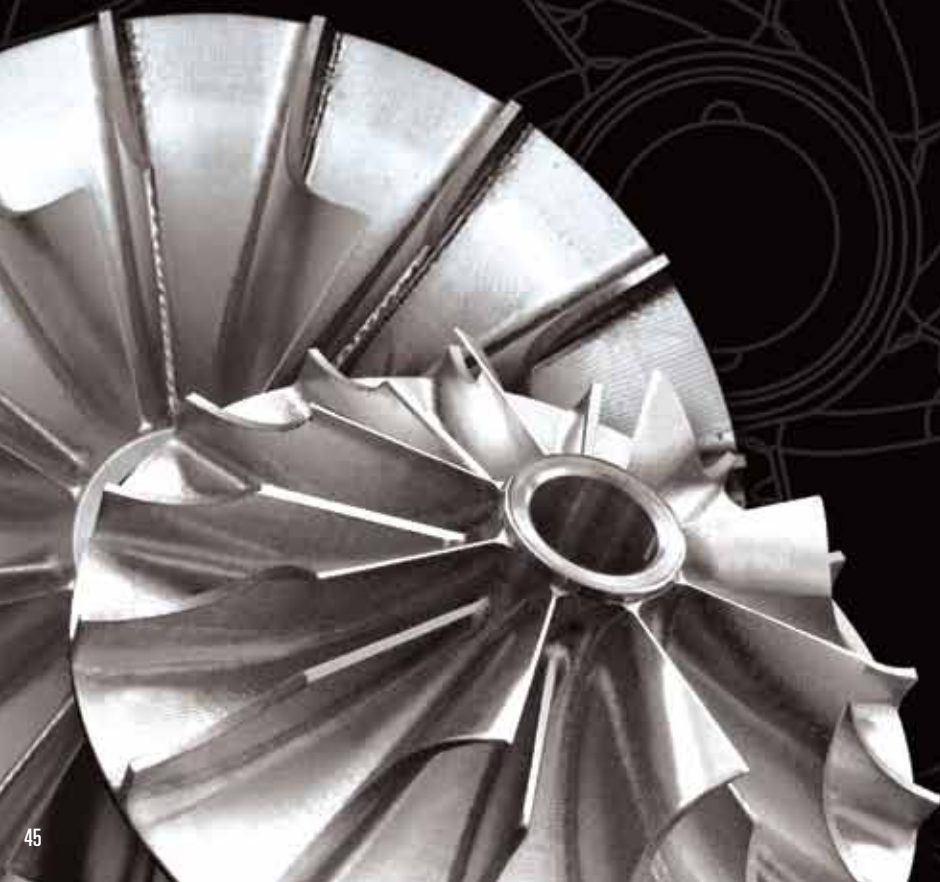

This oil pump does not require priming at start-up, and oil changes are only required every 6,000 miles.

Instead of being forced to utilize engine oil or the grease in sealed bearings, ProCharger superchargers are lubricated with an aerospace-quality synthetic oil specifically engineered for high speed applications.

ProCharger's self-contained design eliminates the heat that is transferred to a supercharger by engine-oiled designs and also avoids the possibility of supercharger damage that results from clogged oil lines or contaminated engine oil.

ProCharger Supercharger Models - Made in the USA!

ProCharger P-1SC & P-1SC-1: The industry's first, self-contained, gear driven supercharger features a 4.10:1 step-up ratio and can support up to 825 horsepower.

ProCharger D-1SC: Using a 4.10:1 step-up ratio, the self-contained D-1SC's larger-diameter impeller can support up to 925 horsepower.

ProCharger F-Series: With step-up ratios as high as 6.24:1, these record-setting, self-contained ProCharger models feature a patented, high-speed compound bearing design and provide operating speeds unmatched by any other line of superchargers on the market. ProCharger F-Series superchargers truly are the Ultimate Power Adder in today's ultra-high horsepower street, strip and extreme racing applications.

For more information, visit: www.procharger.com/models



Proven Leadership

TIMELINE OF POWER

1994



ProCharger introduces the first air-to-air intercooled aftermarket supercharger system, featuring the P600 ProCharger supercharger.



ProCharger introduces the first blow-through centrifugal supercharger kit for carbureted Chevy "muscle cars".

State-of-the-art, CNC-machined billet impellers, a ProCharger exclusive, are introduced with the P600B. Designed for use with big blocks and intercooling, the P600B outflowed other street-legal models by more than 65% and 16 years later still outflows comparable models by over 20%.

1995-97

An intercooled ProCharger system is the first to become 50 state legal with more than 8 psi of boost.



ProCharger introduces a supercharger system for the L98 Tuned Port Injection Corvettes in late 1995. Using either a P600B or D-1 ProCharger, owners can now bolt on up to 75% more power! This is the first and only intercooled supercharger system for L98 Corvettes.



ProCharger is the first centrifugal supercharger manufacturer to successfully supercharge marine engines and is also the first to offer intercooling for the extremely demanding marine market.



1998-99

The ProCharger D-1 supercharger is the first race supercharger offered with a warranty and features an over-sized impeller shaft, a 4.44:1 step-up ratio and dual support bearings - all ProCharger exclusives.



ATI / ProCharger moves into their own, newly-constructed, state-of-the-art manufacturing facility. The new location serves as engineering, R&D, technical service, customer service and marketing headquarters, leading to a period of unprecedented product expansion.



In 1998, ProCharger releases the first and only intercooled supercharger systems for LT1 and LT4 Corvettes, with street power gains of 55-60%.



2000



The all-new ProCharger F-Series superchargers (above) dominate racing. Jim Summers becomes the first Pro 5.0 racer to run 7.20's with a stunning 7.26 @ 193 mph and joins the ProCharger staff in 2002.



ProCharger is the first to produce a self-contained, gear-driven supercharger: the P-1SC. The patented design requires no external oil lines and becomes the standard by which other centrifugal superchargers are measured.

An industrial customer uses a D-1 ProCharger to win a U.S. Air Force contract for an aircraft deicing system which utilizes forced air. The D-1 defeats all centrifugal competitors.

2001-02



Self-contained ProChargers produce 2,000+ hp on 400 cid small blocks and dominate all others at the race track.

Serving notice to the drag racing world, ProCharger is the first centrifugal supercharger to power racers into the 6's.



In 2001, ProCharger introduces the first air-to-air intercooled supercharger system for the high-tech LS1 Corvette, (above) followed closely by the early 2002 release of an industry-leading system for the awesome new LS6-equipped Z06 Corvette.



2003-04

ProCharger's F-3 superchargers firmly establish themselves as the dominant centrifugal supercharger in racing and other ultra-high horsepower applications. The innovative and patented compound bearing and advanced impeller designs provide outstanding power and championship-winning consistency.



Having outgrown their existing facility, ProCharger breaks ground on a major building expansion.

Racers win 5 National Championships and set 10 National records using self-contained ProCharger superchargers.



After being outlawed for years, a ProCharger racer wins the first centrifugal championship in NHRA competition. ProCharger racers are now producing more than 2,500 hp with gasoline and 3,000 hp using methanol.

2005-06

GM releases an all-new C6 Corvette, with all new body work, exposed headlights and a potent 6.0L LS2 engine. The new front fascia features a large, centrally-located air inlet that will prove especially beneficial for airflow to the radiator, air filter and a large, ProCharger air-to-air intercooler.



ProCharged versions of the LS2 Corvette (2005 & 06) will earn CARB EO D-365-5, providing a 50-state legal, 600+ horsepower.



ProCharger superchargers make a powerful statement on Discovery Channel's "Monster Garage", adding insane power to an Army Jeep hot rod puller.



2007



LS2•LS3•LS7

2007 is a huge year for ProCharging Corvettes, including the release of complete intercooled systems and tuner kits for LS2 and LS3 C6 Corvettes. A tuner kit for the all-new LS7-powered Z06 Corvette produces more than 700 hp, becoming the first to break 700 hp with an otherwise stock engine.

A ProCharger-powered Chevrolet racer wins the prestigious HOT ROD Drag Week, earning the title: Fastest Street Car in America.



ProCharger-equipped racers win a record-setting 11 International Championships in a season that sees the fastest side-by-side ProCharger race to date: a 6.32 to a 6.41!

2008

ProCharger Intercooled Supercharger Systems for Harley-Davidson® V-twin engines earn "Performance Product of the Year."



Performance Product of the Year

A ProCharged Corvette earns the title, "Fastest IRS C5" with an amazing 9.24 @ 145 mph.

Another ProCharged racer wins HOT ROD's Pump Gas Drags, becoming the Fastest Pump Gas car in America. At Bonneville, ProCharger-power strikes the salt flats with the World's Fastest Camaro and World's Fastest Production Mustang both running ProCharger superchargers.



ProCharger becomes a sponsor at the newly renovated and expanded National Corvette Museum in Bowling Green, KY

2009-10

ProCharger introduces a helical gearset option for noise reduction in P-1SC, P-1SC-1 and D-1SC superchargers, becoming the first company to offer customers their choice of supercharger sound levels.



ProCharger's industrial counterpart, Inovair, begins shipping high-efficiency compressors for 24/7 continuous duty pneumatic conveying and other applications.

ProCharger introduces an A-1 model, the industry's smallest self-contained, gear driven supercharger, for the rapidly expanding powersports market.

ProCharger releases the first 100% complete air-to-air intercooled supercharger system for the legendary Z06's LS7 engine. *Vette Magazine* confirms it: 700+ horsepower and everyday driveability and reliability.



For Whatever Moves You



The **ULTIMATE Power Adder**[®]

As a Corvette owner, you appreciate balanced, world-class power, performance and reliability. So why settle for anything less out of the other vehicles in your garage?

As the leading aftermarket manufacturer of fully designed and engineered intercooled supercharger solutions, ProCharger has the broadest product range in the industry. Period. From the four door family sedan, to pickup trucks, SUVs, classic muscle cars and all-out race and track cars, chances are ProCharger has a supercharger solution for you.

Or, if your idea of high-performance freedom

involves just two wheels, check out the award-winning design and technology of the ProCharger V-Twin Intercooled Supercharger Systems for Harley-Davidson[®] motorcycles. With systems available for H-D motorcycles from 1984 up to current models, a ProCharger V-Twin supercharger system will put you at the front of the pack, both on the road and at the show.

And if water is more your style, ProCharger has many marine applications for MerCruiser[®]-equipped and modified high horsepower boats to get you that big, reliable power increase you've been craving. Visit ProCharger.com/marine for more information.



Procharge Your Life

Get ProCharger Catalogs and Branded Items Online

Check out the online versions of ProCharger's industry-leading catalogs and showcase your pride with a wide assortment of ProCharger-branded items. From t-shirts and license plate frames, to gauges and wall clocks, visit ProCharger.com/store to see the latest additions.



Stay up to speed with the ProCharger Blog

Keep up with all the latest news, events and amazing, real-world customer and racer accomplishments via the ProCharger Blog, located at ProCharger.com/supercharger/blog.





For Generations C6 • C5 • C4

Accessible Technologies, Inc. • 14801 W. 114th Terrace • Lenexa, KS 66215 • Ph:913.338.2886 • www.ProCharger.com

All of us here at ATI encourage you to use your new found ProCharger power responsibly. Please drive safely, and be respectful of your fellow motorists.
And if you feel the need to race, don't do it on the street – take it to the track!

Corvette® is a registered trademark of General Motors Corporation. This name is used for descriptive purposes only; none of the products herein are authorized by, sponsored by, affiliated with, or otherwise approved by General Motors Corporation. Harley-Davidson® is a registered trademark of Harley-Davidson, Inc. MerCruiser® is a registered trademark of Brunswick Corporation.

© Copyright 2010, Accessible Technologies, Inc. 9/10

